

Solid state relay modules quick selection table

These tables allow you to quickly select only the items, then check if all product's technical data meet your application requirements.

Input modules

Number of channels	Input voltage	Applicable load		Notes	Type	Cat. No.	Page
		Voltage	Current				
1	5...24 Vdc	5...48 Vdc	3 A	(2)	O332060	XO332060	130
1	5...24 Vdc	5...48 Vdc	500 mA	(2)	CWOT 6-2082	X766082	136
1	12...24 Vdc	5...48 Vdc	500 mA	(2)	CWOT 6-2083	X766083	135
1	12...24 Vdc	5...48 Vdc	5 A	(1)	CM1S024E	XCM1S024E	131
1	24 Vdc	5...48 Vdc	2 A	(1)	CM1S024	XCM1S024	131
1	5...12 Vdc	5...24 Vdc	5 A	(2) (4)	CKS15NA	XCKS15NA	133
1	5...24 Vdc	5...24 Vdc	30 mA	(2)	CKS1S	XCKS1S	136
1	24 Vdc	5...24 Vdc	5 A	(2) (4)	CKS15NB	XCKS15NB	133
1	5...24 Vdc	5...24 Vdc	5 A	(2) (5)	CKS15E	XCKS15E	134
1	12...24 Vdc	12...240 Vac	3 A	(1)	CM1T024E	XCM1T024E	132
1	5...24 Vdc	24...240 Vac	4 A	(2)	O332240	XO332240	130
1	24 Vdc	48...240 Vac	2 A	(1)	CM1T024	XCM1T024	132
2	12...24 Vdc	12...24 Vdc	2 x 2.5 A	(2)	CKS22	XCKS22	134
4	24 Vdc	5...48 Vdc	2 A	(1) (3) (4)	R41S24F	XR041S24F	139
4	24 Vdc	5...48 Vdc	2 A	(1) (3)	R42S24	XR042S24	137
4	24 Vdc	48...240 Vac	2 A	(1) (3)	R42T24	XR042T24	138
8	24 Vdc	5...48 Vdc	2 A	(1) (3) (4)	R81S24F	XR081S24F	139
8	24 Vdc	5...48 Vdc	2 A	(1) (3)	R82S24	XR082S24	137
8	24 Vdc	48...240 Vac	2 A	(1) (3)	R82T24	XR082T24	138
8	5...24 Vdc	12...24 Vdc	8 x 2.5 A	(2) (5)	COP082	XCOP082	140
16	24 Vdc	5...48 Vdc	2 A	(1) (3) (4)	R161S24F	XR161S24F	139
16	24 Vdc	5...48 Vdc	2 A	(1) (3)	R162S24	XR162S24	137
16	24 Vdc	48...240 Vac	2 A	(1) (3)	R162T24	XR162T24	138

Notes

(1) version with pluggable relay

(2) version with fixed relay

(3) universal control voltage, negative/positive DC command

(4) output contact with protection fuse

(5) electronic output protection

Solid state 5...24 Vdc single relay

- Fixed relay
- Compact dimensions
- Status LED display

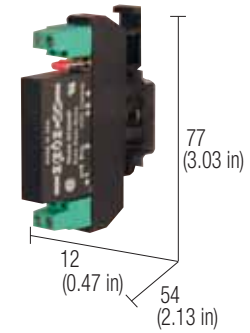
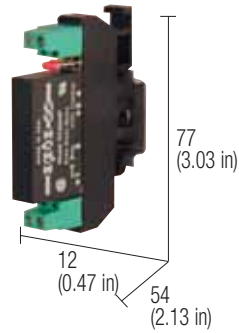

NOTES

(1) Relay model is not binding, they may be modified without prior warning. The technical data shown here is to be considered typical.

BLOCK DIAGRAM

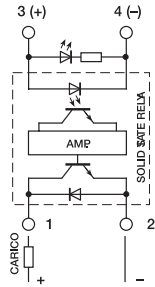

BLOCK DIAGRAM

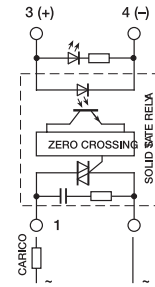

VERSIONS

	Cat. No. X0332060	Cat. No. X0332240
Pluggable relay	—	—
Fixed relay	0332060	0332240

INPUT TECHNICAL DATA

	Cat. No. X0332060	Cat. No. X0332240
Input voltage	4...30 Vdc	4...30 Vdc
Level 1 (high) input signal	> 3 Vdc	> 3 Vdc
Level 0 (low) input signal	< 1 Vdc	< 1 Vdc
Rated current	< 35 mA	< 35 mA
Switching frequency	100 Hz max	100 Hz max
Connection terminals	2.5 mm ² fixed screw type	2.5 mm ² fixed screw type

OUTPUT TECHNICAL DATA

	Cat. No. X0332060	Cat. No. X0332240
Output voltage	5...60 Vdc	24...240 Vac (zero crossing)
Continuous load current	3 A a 20°C (see chart)	4 A a 20°C (see chart)
Max. current	4 A a 20°C (5 A / 5 s - 25 A / 10 ms)	5 A a 20°C (6 A / 5 s - 25 A / 10 ms)
Leakage current 0 signal	1 mA	5 mA
OFF/ON switching time	—	—
Protection circuit	—	10 ms max
Connection terminals	2.5 mm ² fixed screw type	2.5 mm ² fixed screw type

GENERAL TECHNICAL DATA

	Cat. No. X0332060	Cat. No. X0332240
Operating temperature	-20...-60°C (see chart)	-20...-60°C (see chart)
I/O isolation (coil/contact)	4 kVac / 60 s	4 kVac / 60 s
Protection degree	IP 00 IEC529, EN60529	IP 00 IEC529, EN60529
Reference Standard	IEC 664-1, DIN VDE 0110.1	IEC 664-1, DIN VDE 0110.1
Pollution degree	2	2
Overvoltage category	III	III
Modello del relé (1)	OPT022	OPT022
Status display	LED	LED
Housing material	Polyamide UL94V-0	Polyamide UL94V-0
Approx. weight	36 g (1.27 oz)	36 g (1.27 oz)
Mounting information	vertical on rail, allow 4 mm spacing between adjacent components	vertical on rail, allow 4 mm spacing between adjacent components

MOUNTING ACCESSORIES

	Cat. No. X0332060	Cat. No. X0332240
Mounting rail type according to IEC60715/TH35	PR/3/AC, PR/3/AS	PR/3/AC, PR/3/AS
Mounting rail type according to IEC60715/G32	PR/DIN/AC - PR/DIN/AS - PR/DIN/AL	PR/DIN/AC - PR/DIN/AS - PR/DIN/AL
Replacement relay (1)	—	—
Screw type jumper	—	—
red	—	—
white	—	—
blue	—	—

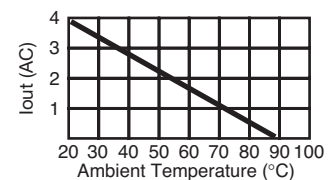
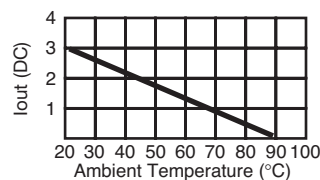

Solid state 12-24 Vdc single relay

- Low cost
- For DC load (S version)
- Pluggable relay
- Screw type jumper available
- Status LED display

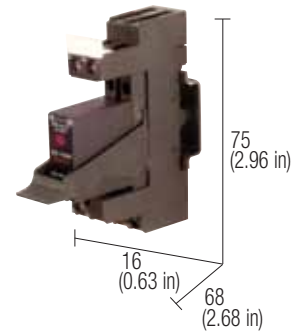
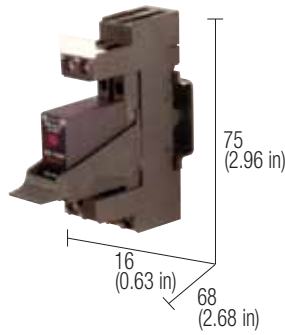

NOTES

(1) Relay model is not binding, they may be modified without prior warning. The technical data shown here is to be considered typical.

This series can be mounted without any spacing between adjacent components.

BLOCK DIAGRAM

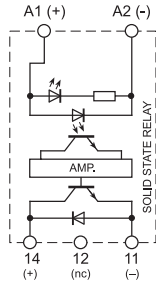

BLOCK DIAGRAM

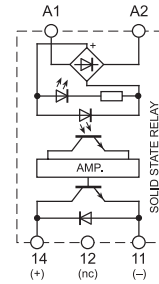

VERSIONS

Pluggable relay
Fixed relay

Cat. No. XCM1S024

CM1S024

—

Cat. No. XCM1S024E

CM1S024E

—

INPUT TECHNICAL DATA

Input voltage	24 Vdc (19.2...28.8 Vdc)
Level 1 (high) input signal	> 19.2 Vdc
Level 0 (low) input signal	< 1 Vdc
Rated current (1 channel)	< 20 mA
Switching frequency	100 Hz max
Connection terminals	2.5 mm ² fixed screw ty ^e

Input voltage	12-24 Vdc (10...30 Vdc)
Level 1 (high) input signal	> 10 Vdc
Level 0 (low) input signal	< 6 Vdc
Rated current (1 channel)	< 26 mA
Switching frequency	100 Hz max
Connection terminals	2.5 mm ² fixed screw ty ^e

OUTPUT TECHNICAL DATA

Output voltage	3...50 Vdc
Continuous load current	2.5 A a 40°C
Max. current	4 A / 5 s - 20 A / 10 ms
Leakage current 0 signal	0.1 mA
OFF/ON switching time	100 μs / 1 ms
Protection circuit	diode
Connection terminals	2.5 mm ² fixed screw ty ^e

Output voltage	5...60 Vdc
Continuous load current	5 A a 50°C
Max. current	—
Leakage current 0 signal	10 μA
OFF/ON switching time	100 μs / 1 ms
Protection circuit	diode
Connection terminals	2.5 mm ² fixed screw ty ^e

GENERAL TECHNICAL DATA

Operating temperature	-20...-60°C over 40°C apply a derating of 0.05A/°C
I/O isolation (coil/contact)	2.5 kVac / 60 s
Protection degree	IP 00 IEC529, EN60529
Reference Standard	IEC 664-1, DIN VDE 0110.1
Pollution degree	3
Overvoltage category	III
Modello del relé (1)	HF JGX-40F
Status display	LED
Housing material	Polyamide UL94V-0
Approx. weight	—
Mounting information	vertical on rail adjacent without gap

Operating temperature	-20...-60°C over 40°C apply a derating of 0.1A/°C
I/O isolation (coil/contact)	4 kVac / 60 s
Protection degree	IP 00 IEC529, EN60529
Reference Standard	IEC 664-1, DIN VDE 0110.1
Pollution degree	3
Overvoltage category	III
Modello del relé (1)	ELCO SSR91-60B
Status display	LED
Housing material	Polyamide UL94V-0
Approx. weight	—
Mounting information	vertical on rail adjacent without gap

MOUNTING ACCESSORIES

Mounting rail type according to IEC60715/TH35	PR/3/AC, PR/3/AS
Mounting rail type according to IEC60715/G32	—
Replacement relay (1)	Cat. No. 8904404
Screw type jumper	Cat. No. XCMB16B
black	—
white	—
blue	—

Mounting rail type according to IEC60715/TH35	PR/3/AC, PR/3/AS
Mounting rail type according to IEC60715/G32	—
Replacement relay (1)	Cat. No. 8904402
Screw type jumper	Cat. No. XCMB16B
black	—
white	—
blue	—

Solid state 12-24 Vdc single relay

- Low cost
- For AC load (T version)
- Pluggable relay
- Screw type jumper available
- Status LED display

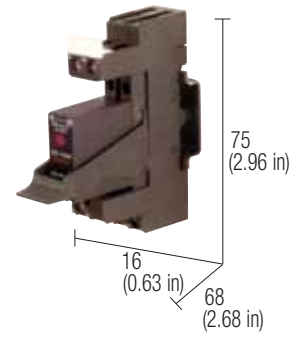
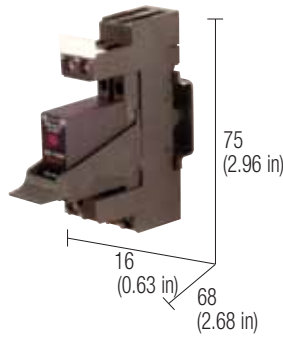

NOTES

(1) Relay model is not binding, they may be modified without prior warning. The technical data shown here is to be considered typical.

This series can be mounted without any spacing between adjacent components.

BLOCK DIAGRAM

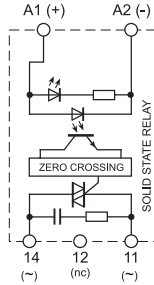

BLOCK DIAGRAM

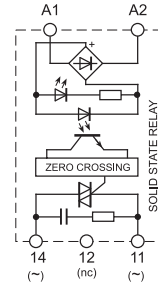

VERSIONS

Pluggable relay
Fixed relay

Cat. No. XCM1T024

CM1T024

—

Cat. No. XCM1T024E

CM1T024E

—

INPUT TECHNICAL DATA

Input voltage	24 Vdc (19.2...28.8 Vdc)
Level 1 (high) input signal	> 19.2 Vdc
Level 0 (low) input signal	< 1 Vdc
Rated current (1 channel)	< 20 mA
Switching frequency	100 Hz max
Connection terminals	2.5 mm ² fixed screw type

Input voltage	12-24 Vdc (10...30 Vdc)
Level 1 (high) input signal	> 10 Vdc
Level 0 (low) input signal	< 6 Vdc
Rated current (1 channel)	< 26 mA
Switching frequency	100 Hz max
Connection terminals	2.5 mm ² fixed screw type

OUTPUT TECHNICAL DATA

Output voltage	48...240 Vac (zero crossing)
Continuous load current	2.5 A a 40°C
Max. current	4 A / 5 s - 20 A / 10 ms
Leakage current 0 signal	1.5 mA
OFF/ON switching time	10 ms / 10 ms max.
Protection circuit	—
Connection terminals	2.5 mm ² fixed screw type

Output voltage	20...240 Vac (zero crossing)
Continuous load current	3 A a 50°C
Max. current	—
Leakage current 0 signal	1 mA
OFF/ON switching time	10 ms / 10 ms max.
Protection circuit	—
Connection terminals	2.5 mm ² fixed screw type

GENERAL TECHNICAL DATA

Operating temperature	-20...-60°C over 40°C apply a derating of 0.05A/°C
I/O isolation (coil/contact)	2.5 kVac / 60 s
Protection degree	IP 00 IEC529, EN60529
Reference Standard	IEC 664-1, DIN VDE 0110.1
Pollution degree	3
Overtoltage category	III
Modello del relé (1)	HF JGX-40F
Status display	LED
Housing material	Polyamide UL94V-0
Approx. weight	—
Mounting information	vertical on rail adjacent without gap

Operating temperature	-20...-60°C over 40°C apply a derating of 0.1A/°C
I/O isolation (coil/contact)	4 kVac / 60 s
Protection degree	IP 00 IEC529, EN60529
Reference Standard	IEC 664-1, DIN VDE 0110.1
Pollution degree	3
Overtoltage category	III
Modello del relé (1)	ELCO SSR91-60B
Status display	LED
Housing material	Polyamide UL94V-0
Approx. weight	—
Mounting information	vertical on rail adjacent without gap

MOUNTING ACCESSORIES

Mounting rail type according to IEC60715/TH35	PR/3/AC, PR/3/AS
Mounting rail type according to IEC60715/G32	—
Replacement relay (1)	Cat. No. 8904405
Screw type jumper	Cat. No. XCMB16B
black	—
white	—
blue	—

Mounting rail type according to IEC60715/TH35	PR/3/AC, PR/3/AS
Mounting rail type according to IEC60715/G32	—
Replacement relay (1)	Cat. No. 8904403
Screw type jumper	Cat. No. XCMB16B
black	—
white	—
blue	—

Solid state 12-24 Vdc single relay with fuse

- 5 A / 24 Vdc rated current
- Common negative or positive input
- Overload, short-circuit protected output with replaceable fuse
- Status LED display, reverse polarity protection
- 6 mm wide
- Plug-in jumper available

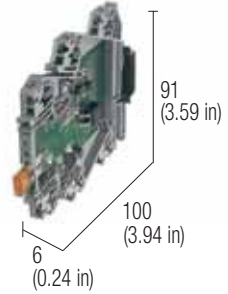
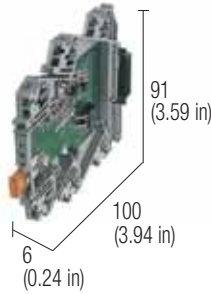

NOTES

(1) The fast blow-out fuse is calibrated to protect the output stage of the module and it is connected in series to the positive pole; it is possible to replace the fuse with lower rated current values, selected to protect also the load and its wires; a fuse having a current rating higher than 5 A does not protect the output against short circuit and overloads.
 (2) In order to assure the IP20 protection degree, the last module must be protected and insulated using the CK/P.T end section.

BLOCK DIAGRAM

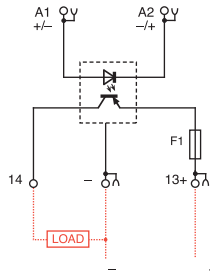

BLOCK DIAGRAM

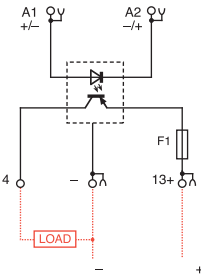

VERSIONS

Pluggable relay
Fixed relay

Cat. No. XCKS15NA

CKS15NA

Cat. No. XCKS15NB

CKS15NB

INPUT TECHNICAL DATA

Input voltage	4.5...12 Vdc
Level 1 (high) input signal	≥4.5 Vdc
Level 0 (low) input signal	≤4 Vdc
Rated current	≤5 mA @ 12 Vdc

Input voltage	4.5...12 Vdc
Level 1 (high) input signal	≥4.5 Vdc
Level 0 (low) input signal	≤4 Vdc
Rated current	≤5 mA @ 12 Vdc

Input voltage	19...30 Vdc
Level 1 (high) input signal	≥ 20 Vdc
Level 0 (low) input signal	≤18 Vdc
Rated current	≤ 5 mA @ 24 Vdc

OUTPUT TECHNICAL DATA

Output voltage	5.2...60 Vdc, max. 100 V (peak)
Continuous load current	5 A / 24 Vdc @ 25°C
Max. current	7.5 A / 1 s, 25 A / 50 ms
Min. applicable load	5.2 V / 10 mA
Leakage current 0 signal	25 µA @ 60 Vdc between 13 and 14
Isolation between open contacts	3 kVac / 60 s
Protection fuse (1)	F 5 A

Output voltage	5.2...60 Vdc, max. 100 V (peak)
Continuous load current	5 A / 24 Vdc @ 25°C
Max. current	7.5 A / 1 s, 25 A / 50 ms
Min. applicable load	5.2 V / 10 mA
Leakage current 0 signal	25 µA @ 60 Vdc between 13 and 14
Isolation between open contacts	3 kVac / 60 s
Protection fuse (1)	F 5 A

Output voltage	5.2...60 Vdc, max. 100 V (peak)
Continuous load current	5 A / 24 Vdc @ 25°C
Max. current	7.5 A / 1 s, 25 A / 50 ms
Min. applicable load	5.2 V / 10 mA
Leakage current 0 signal	25 µA @ 60 Vdc between 13 and 14
Isolation between open contacts	3 kVac / 60 s
Protection fuse (1)	F 5 A

GENERAL TECHNICAL DATA

Operating temperature	-20...+60°C
I/O isolation	3 kVac / 60 s
Max. switching frequency	400 Hz max.
Protection degree	IP20 IEC529 EN60529
Reference Standard	IEC 664-1, EN50081-1
Pollution degree	2
Overvoltage category	II
Connection terminals	2.5 mm ² (AWG 14), AWG26-14 spring type
Housing material	Polyamide UL94V-0
Approx. weight	32 g (1.13 oz)
Mounting information	vertical on rail adjacent without gap

Operating temperature	-20...+60°C
I/O isolation	3 kVac / 60 s
Max. switching frequency	400 Hz max.
Protection degree	IP20 IEC529 EN60529
Reference Standard	IEC 664-1, EN50081-1
Pollution degree	2
Overvoltage category	II
Connection terminals	2.5 mm ² (AWG 14), AWG26-14 spring type
Housing material	Polyamide UL94V-0
Approx. weight	32 g (1.13 oz)
Mounting information	vertical on rail adjacent without gap

Operating temperature	-20...+60°C
I/O isolation	3 kVac / 60 s
Max. switching frequency	400 Hz max.
Protection degree	IP20 IEC529 EN60529
Reference Standard	IEC 664-1, EN50081-1
Pollution degree	2
Overvoltage category	II
Connection terminals	2.5 mm ² (AWG 14), AWG26-14 spring type
Housing material	Polyamide UL94V-0
Approx. weight	32 g (1.13 oz)
Mounting information	vertical on rail adjacent without gap

MOUNTING ACCESSORIES

Mounting rail type according to IEC60715/TH35-7,5	PR/3/AC, PR/3/AC/ZB, PR/3/AS, PR/3/AS/ZB
Mounting rail type according to IEC60715/G32	—
Replacement relay (1)	—
Plug-in jumper	Cat. No. PTCK42 (42 poles)
Marking tags	blank Cat. No. NU0851

Mounting rail type according to IEC60715/TH35-7,5	PR/3/AC, PR/3/AC/ZB, PR/3/AS, PR/3/AS/ZB
Mounting rail type according to IEC60715/G32	—
Replacement relay (1)	—
Plug-in jumper	Cat. No. PTCK42 (42 poles)
Marking tags	blank Cat. No. NU0851

Mounting rail type according to IEC60715/TH35-7,5	PR/3/AC, PR/3/AC/ZB, PR/3/AS, PR/3/AS/ZB
Mounting rail type according to IEC60715/G32	—
Replacement relay (1)	—
Plug-in jumper	Cat. No. PTCK42 (42 poles)
Marking tags	blank Cat. No. NU0851

End plate

Cat. No. XCKPT

Cat. No. XCKPT

Solid state 12-24 Vdc single relay with electronic

- Electronic protection from short circuit, overload, overtemperature
- Input and output status LED
- Output extravoltage suppressor diode
- Extralow current absorbing
- Plug-in jumper available

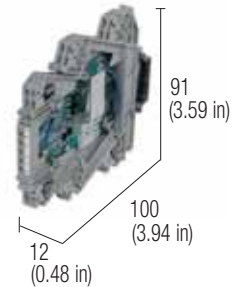
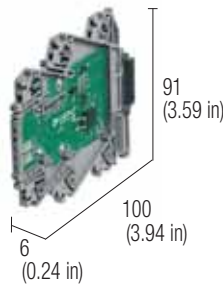

NOTES

- (1) Maximum output current of each channel depends on surrounding air temperature, on the number of output temporarily active and on the current flowing through them; the given value is measured with 4 active outputs and 4 not active
- (2) All outputs are overcurrent and overtemperature; when ovd or ovt protections cuts off the output current, the output display led turns off or reduces its light depending on ovd degree; the output turns on automatically when the ovd or ovt are removed.

BLOCK DIAGRAM

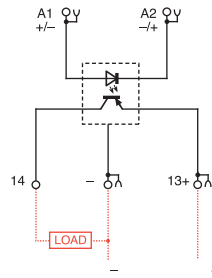

BLOCK DIAGRAM

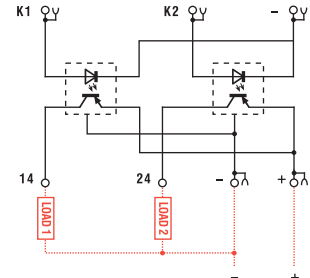

VERSIONS

Pluggable relay
Fixed relay

Cat. No. XCKS15E

CKS15E

Cat. No. XCKS22

CKS22

INPUT TECHNICAL DATA

Input voltage	5...24 Vdc (4.2...32 Vdc)
Level 1 (high) input signal	> 3.5 Vdc
Level 0 (low) input signal	< 3.5 Vdc
Rated current	≤ 5 mA @ 24 Vdc
Input channels	1

5...24 Vdc (4.2...32 Vdc)

> 3.5 Vdc

< 3.5 Vdc

≤ 5 mA @ 24 Vdc

1

12...24 Vdc (range 8...33 Vdc)

≥ 12 Vdc

≤ 11.7 Vdc

≤ 5 mA @ 24 Vdc

2 with common negative

OUTPUT TECHNICAL DATA

Output voltage	5...24 Vdc (5...32 Vdc)
Continuous load current	5 A / 24 Vdc @ 45°C (1)
Max. current	7.5 A / 60 s, 2.5 A / 50 ms peak (1)
Min. applicable load	5.2 V / 100 mA
Max. switching frequency	200 Hz max.
Leakage current 0 signal	< 25 μA @ 24 Vdc
Isolation between open contacts	—
Protection	electronic from overload, overtemperature (2)

5...24 Vdc (5...32 Vdc)

5 A / 24 Vdc @ 45°C (1)

7.5 A / 60 s, 2.5 A / 50 ms peak (1)

5.2 V / 100 mA

200 Hz max.

< 25 μA @ 24 Vdc

—

electronic from overload, overtemperature (2)

12...24 Vdc (range 5...33 Vdc)

2 x 2.5 A / 24 Vdc @ 45°C

4.4 A

10 mA

—

1 mA @ 24 Vdc

3 kVac / 60 s

—

GENERAL TECHNICAL DATA

Operating temperature	-20 ... +60°C (with therml protection) (2)
I/O isolation	3 kVac / 60 s
Max. switching frequency	—
Protection degree	IP20 IEC529 EN60529
Reference Standard	IEC 664-1, EN50081-1
Pollution degree	2
Overvoltage category	II
Connection terminals	2.5 mm ² AWG26-14 fixed spring type
Housing material	Polyamide UL94V-0
Approx. weight	30 g (1.06 oz)
Mounting information	vertical on rail adjacent without gap

-20 ... +60°C (with therml protection) (2)

3 kVac / 60 s

—

IP20 IEC529 EN60529

IEC 664-1, EN50081-1

2

II

2.5 mm² AWG26-14 fixed spring type

Polyamide UL94V-0

30 g (1.06 oz)

vertical on rail adjacent without gap

-20 ... +60°C (with therml protection) (2)

3 kVac / 60 s

1 kHz (Ton <500 ms / Toff <500 ms)

IP20 IEC529 EN60529

IEC 664-1, EN50081-1

2

II

2.5 mm² AWG26-14 fixed spring type

Polyamide UL94V-0

32 g (1.13 oz)

vertical on rail adjacent without gap

MOUNTING ACCESSORIES

Mounting rail type according to IEC60715/TH35-7,5	PR/3/AC, PR/3/AC/ZB, PR/3/AS, PR/3/AS/ZB
Mounting rail type according to IEC60715/G32	—
Replacement relay (1)	—
Plug-in jumper	Cat. No. PTCK42 (42 poles)
Marking tags	blank Cat. No. NU0851

PR/3/AC, PR/3/AC/ZB, PR/3/AS, PR/3/AS/ZB

—

—

Cat. No. PTCK42 (42 poles)

blank
Cat. No. NU0851

PR/3/AC, PR/3/AC/ZB, PR/3/AS, PR/3/AS/ZB

—

—

Cat. No. PTCK42 (42 poles)

blank
Cat. No. NU0851

End plate

Cat. No. XCKPT

Cat. No. XCKPT

Solid state 12-24 Vdc single relay with electronic SPDT

- 10...40 Vdc rated voltage
- Output with SPDT simulation
- Output voltage 5...48 Vdc 500 mA
- Max switching frequency 1 KHz
- I/O isolation 3.75 KV

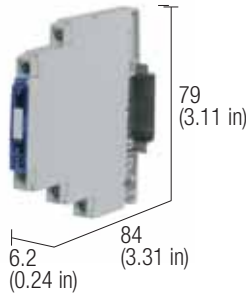

NOTES

Compared with standard relays, solid state relays offers many advantages: much longer life, higher switching frequency, lower EMI emissions, higher vibrations withstand capability, wider input voltage range and 70% lower input current. The output of solid state relays is a N.O. type "contact" and up to now SPDT type was not available, forcing to use a standard relay when SPDT function was required. Thanks to a new technology, this new solid state relay offers all the advantages of solid state relays with a SPDT contact output type, making a step ahead possible.

BLOCK DIAGRAM

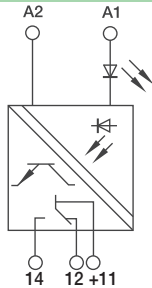

VERSIONS

- Pluggable relay
- Fixed relay

Cat. No. X766083

CWOT 6-2083

INPUT TECHNICAL DATA

Input signal	24 Vdc (range 10...40 Vdc)
Level 1 (high) input signal (ON)	>5 Vdc
Level 0 (low) input signal (OFF)	<5 Vdc
Rated current	6 mA
Protection device	suppressor diode

OUTPUT TECHNICAL DATA

Output signal	5...48 Vdc
Continuous load current	10...500 mA
Switching delay	12 μs ON / 12 μs OFF
Protection device	suppressor diode
Output Type	NPN / PNP transistor, with changeover contact simulation

GENERAL TECHNICAL DATA

Operating temperature	-25 ...+60°C
I/O isolation	3.75 KVac / 60 s
Max. switching frequency	<1 KHz
Protection degree	IP 20 IEC529 EN60529
Reference Standard	IEC 664-1, DIN VDE
Pollution degree	2
Overvoltage category	III
Connection terminals	2.5 mm ² fixed screw type
Housing material	PPE
Approx. weight	29 g (1.02 oz)
Mounting information	vertical on rail adjacent without gap

MOUNTING ACCESSORIES

Mounting rail type according to IEC60715/TH35	PR/3/AC, PR/3/AC/ZB, PR/3/AS, PR/3/AS/ZB
Mounting rail type according to IEC60715/G32	—
Replacement relay (1)	—
Plug-in jumper	—
Marking tags	blank
	printed
	printed
End plate	—

Signal optoisolators

- Suitable for isolation and transmission of digital signal with high frequency
- Status LED display
- 5, 12 and 24 rated voltage
- I/O isolation

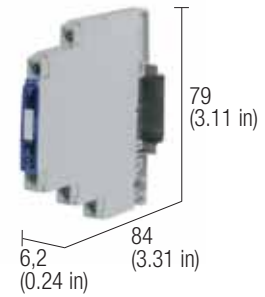
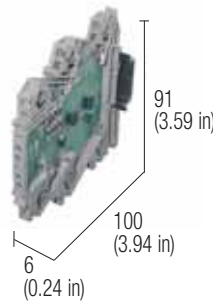

NOTES

(1) Version available upon request.
 CKS1S can isolate I/O high frequency signal circuits (encoders, counters etc.) to eliminate influence of different ground reference voltages and ground loops, thus reducing EMI noise influence on signal transmission of sensitive signals; it is always recommended to use balanced type shielded cables (two signal wires + shield); at transmission frequencies higher than 25 Hz the LED light appears constant, it is to be intended as "transmission ON" signal.

BLOCK DIAGRAM

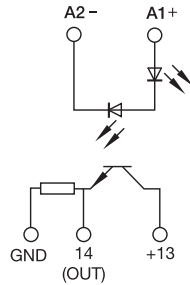

BLOCK DIAGRAM

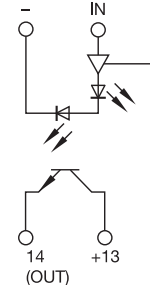

VERSIONS

Cat. No. XCKS1S
 CKS1S

Cat. No. X766082
 CWOT 6-2082

INPUT TECHNICAL DATA

Input signal
Level 1 (high) input signal (ON)
Level 0 (low) input signal (OFF)
Rated current

3...30 Vdc
≥ 3 Vdc
≤ 3 Vdc
≤ 10 mA @ 24 Vdc

4.5...28 Vdc
>4.2 Vdc
<2.7 Vdc
0.1 mA

OUTPUT TECHNICAL DATA

Output signal
Continuous load current
Min. applicable load
Switching delay

3...30 Vdc
80 mA / 30 Vdc @ 25°C
10 mV / 2 mA
—

5...48 Vdc
10...500 mA
—
12 μs ON / 12 μs OFF

GENERAL TECHNICAL DATA

Operating temperature
I/O isolation
Max. switching frequency
Protection degree
Reference Standard
Pollution degree
Overvoltage category
Connection terminals
Housing material
Approx. weight
Mounting information

-20...+60°C
3 kVac / 60 s
100 kHz max. duty cycle 50/50, 70/30 max
IP 20 IEC529 EN60529
IEC 664-1, EN50081-1
2
II
2.5 mm ² (AWG 14), AWG26-14 spring type
Polyamide UL94V-0
32 g (1.13 oz)
vertical on rail adjacent without gap

-25...+60°C
3.75 kVac / 60 s
<20 KHz
IP 20 IEC529 EN60529
IEC 664-1, DIN VDE
2
III
2.5 mm ² , AWG26-14 a vite
PPE
29 g (1.02 oz)
vertical on rail adjacent without gap

MOUNTING ACCESSORIES

Mounting rail type according to IEC60715/TH35
Mounting rail type according to IEC60715/G32
Replacement relay (1)
Plug-in jumper
Marking tags
End plate

PR/3/AC, PR/3/AC/ZB, PR/3/AS, PR/3/AS/ZB

—
Cat. No. PTCK42 (42 poles)
Cat. No. NU0851
—
—
Cat. No. XCKPT

PR/3/AC, PR/3/AC/ZB, PR/3/AS, PR/3/AS/ZB

—
—
—
—
—
—

Solid state 24 Vdc relay modules

- For DC load
- Pluggable relay
- Status LED display

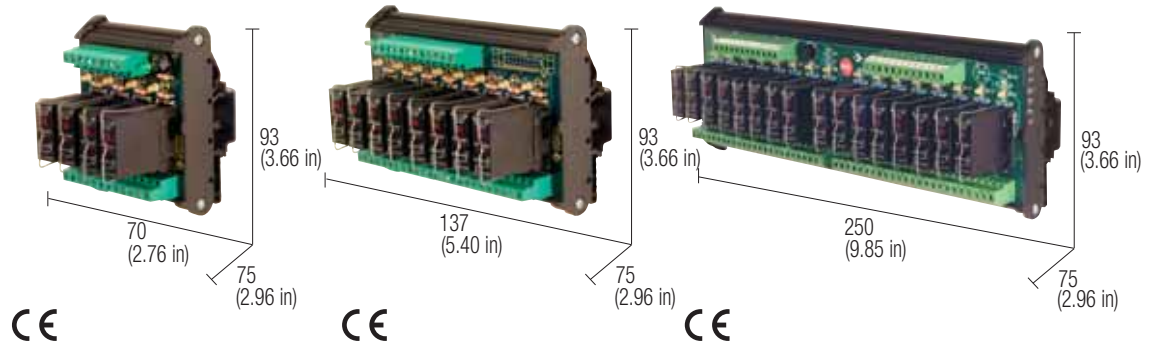

NOTES

(1) Relay model is not binding, they may be modified without prior warning. The technical data shown here is to be considered typical.

POWER SUPPLY

A1 = +	A2 = -	negative common
A1 = -	A2 = +	positive common

BLOCK DIAGRAM

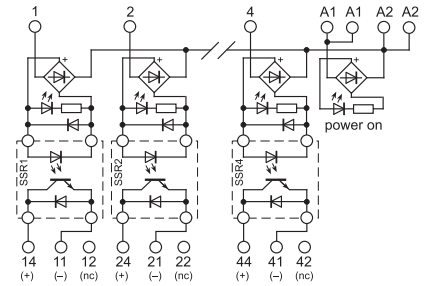

4 relay module

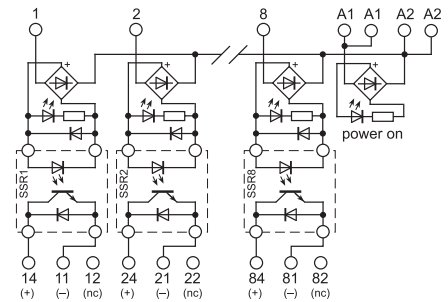

8 relay module

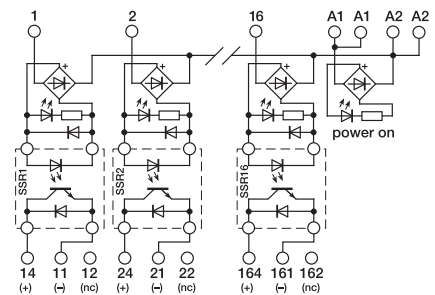

16 relay module

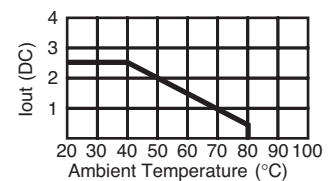

VERSIONS

4 relay module

8 relay module

16 relay module

Cat. No. XR042S24

Cat. No. XR082S24

Cat. No. XR162S24

R42S24

R82S24

R162S24

INPUT TECHNICAL DATA

Input voltage	24 Vdc (19.2...28.8 Vdc)
Level 1 (high) input signal	> 19.2 Vdc
Level 0 (low) input signal	< 1 Vdc
Rated current (1 channel)	< 20 mA
Switching frequency	100 Hz max

OUTPUT TECHNICAL DATA

Output voltage	3...50 Vdc
Continuous load current	2.5 A a 40°C (see chart)
Max. current	4 A / 5 s - 20 A / 10 ms
Leakage current 0 signal	0.1 mA
OFF/ON switching time	100 µs / 1 ms
Protection circuit	diodo
Current of the fuse max.	—

GENERAL TECHNICAL DATA

Operating temperature range	-20...-60°C (see chart)
I/O isolation	2.5 kVac / 60 s
Isolation between output terminals	1 kVac / 60 s (between open contact)
Protection degree	IP 00 IEC 529, EN60529
Overtoltage category / Pollution degree	III / 2
Reference Standard	IEC 664-1, DIN VDE 0110.1
Status display	green LED / yellow LED
Connection terminal	2.5 mm ² fixed screw type
Housing material	UL94V-0 plastic material
Approx. weight	207 g (7.31 oz) 379 g (13.38 oz) 756 g (26.69 oz)
Mounting information	vertical on rail adjacent without gap

MOUNTING ACCESSORIES

Mounting rail type according to IEC60715/TH35	PR/3/AC, PR/3/AC/ZB, PR/3/AS, PR/3/AS/ZB
Mounting rail type according to IEC60715/G32	PR/DIN/AC - PR/DIN/AS - PR/DIN/AL
Replacement relay (1)	Cat. No. 8904404
Screw type jumper	—

Solid state 24 Vdc relay modules

- For AC load
- Pluggable relay
- Status LED display

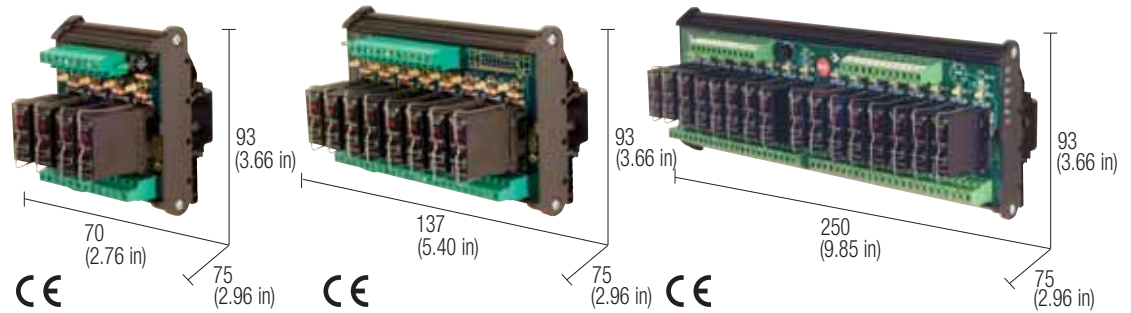

NOTES

(1) Relay model is not binding, they may be modified without prior warning. The technical data shown here is to be considered typical.

POWER SUPPLY

A1 = +	A2 = -	negative common
A1 = -	A2 = +	positive common

BLOCK DIAGRAM

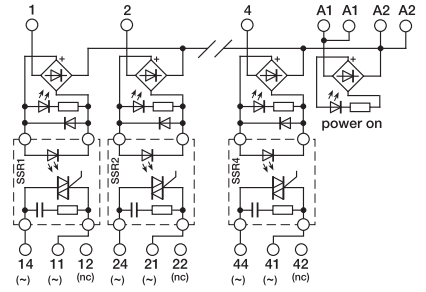

4 relay module

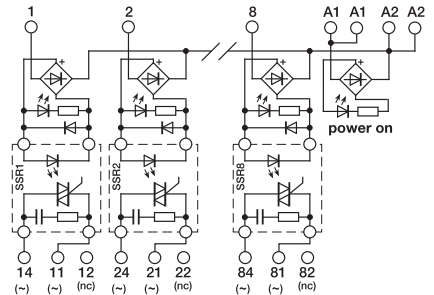

8 relay module

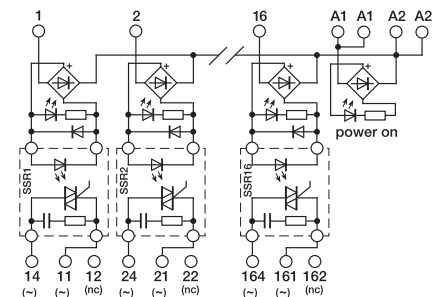

16 relay module

VERSIONS

4 relay module

8 relay module

16 relay module

Cat. No. XR042T24

R42T24

Cat. No. XR082T24

R82T24

Cat. No. XR162T24

R162T24

INPUT TECHNICAL DATA

Input voltage	24 Vdc (19.2...28.8 Vdc)
Level 1 (high) input signal	> 19.2 Vdc
Level 0 (low) input signal	< 1 Vdc
Rated current (1 channel)	< 20 mA
Switching frequency	100 Hz max

OUTPUT TECHNICAL DATA

Output voltage	48...240 Vac (zero crossing)
Continuous load current	2.5 A a 40°C (see chart)
Max. current	4 A / 5 s - 20 A / 10 ms
Leakage current 0 signal	1.5 mA
OFF/ON switching time	10 ms / 10 ms max.
Protection circuit	—
Current of the fuse max.	—

GENERAL TECHNICAL DATA

Operating temperature range	-20...-60°C (see chart)
I/O isolation	2.5 kVac / 60 s
Protection degree	1 kVac / 60 s (between open contact)
Reference Standard	IP 00 IEC 529, EN60529
Pollution degree	III / 2
Overtoltage category	IEC 664-1, DIN VDE 0110.1
Modello del relé (1)	green LED / yellow LED
Status display	2.5 mm ² fixed screw type
Housing material	UL94V-0 plastic material
Approx. weight (4/8/16 relé)	207 g (7.31 oz) 379 g (13.38 oz) 756 g (26.69 oz)
Mounting information	vertical on rail adjacent without gap

MOUNTING ACCESSORIES

Mounting rail type according to IEC60715/TH35	PR/3/AC, PR/3/AC/ZB, PR/3/AS, PR/3/AS/ZB
Mounting rail type according to IEC60715/G32	PR/DIN/AC - PR/DIN/AS - PR/DIN/AL
Replacement relay (1)	Cat. No. 8904405
Screw type jumper	—

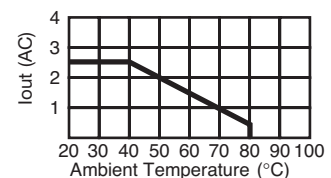

Solid state 24 Vdc relay modules with fuse

- For DC load
- Protection fuse on output
- Pluggable relay
- Status LED display

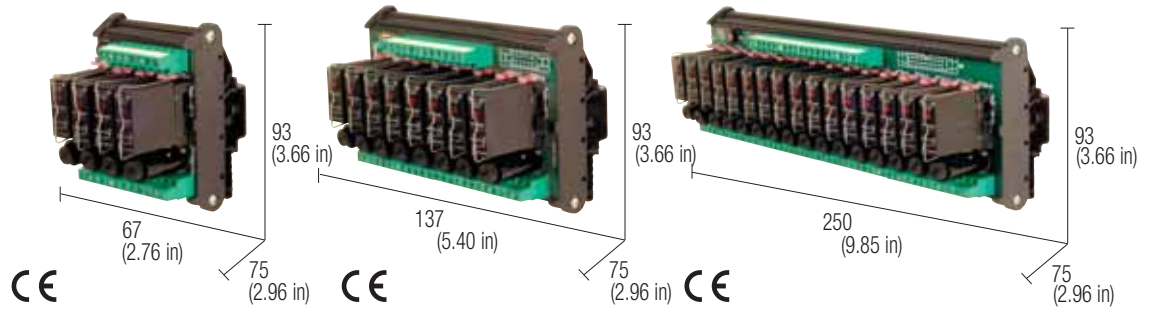

NOTES

- (1) Relay model is not binding, they may be modified without prior warning. The technical data shown here is to be considered typical.
- (2) The fuse must be dimensioned according to load. The max. value of 6.3 A is referred to EN60127-complying fuses and the homologation rated current of the fuse-holder. Fuses of a higher value may damage the fuse-holder and module.

POWER SUPPLY

A1 = +	A2 = -	negative common
A1 = -	A2 = +	positive common

BLOCK DIAGRAM

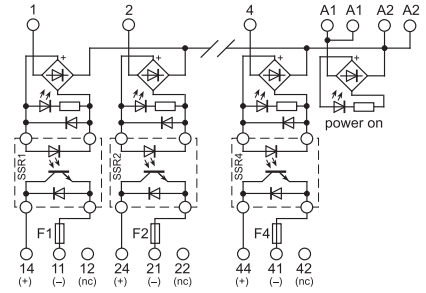

4 relay module

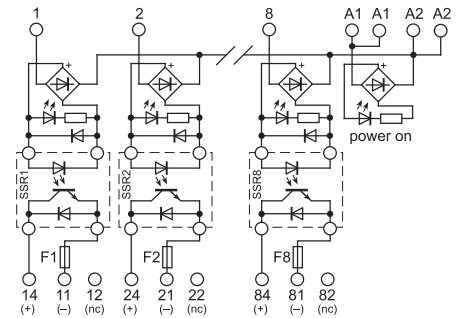

8 relay module

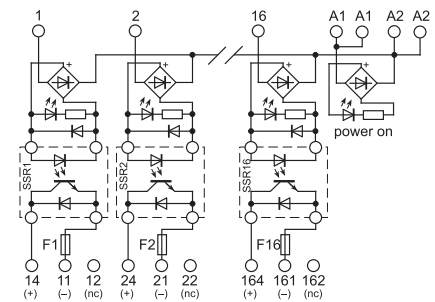

16 relay module

VERSIONS

4 relay module

8 relay module

16 relay module

Cat. No. XR041S24F	Cat. No. XR081S24F	Cat. No. XR161S24F
R41S24F	R81S24F	R161S24F

INPUT TECHNICAL DATA

Input voltage	24 Vdc (19.2...28.8 Vdc)
Level 1 (high) input signal	> 19.2 Vdc
Level 0 (low) input signal	< 1 Vdc
Rated current (1 channel)	< 20 mA
Switching frequency	100 Hz max

OUTPUT TECHNICAL DATA

Output voltage	3...50 Vdc
Continuous load current	2.5 A a 40°C (see chart)
Max. current	4 A / 5 s - 20 A / 10 ms
Leakage current 0 signal	0.1 mA
OFF/ON switching time	100 µs / 1 ms
Protection circuit	diode
Current of the fuse max.	—

GENERAL TECHNICAL DATA

Operating temperature range	-20...-60°C (see chart)
I/O isolation	2.5 KVac / 60 s
Isolation between output terminals	1 KVac / 60 s (between open contact)
Protection degree	IP 00 IEC 529, EN60529
Overtoltage category / Pollution degree	III / 2
Reference Standard	IEC 664-1, DIN VDE 0110.1
Status display	green LED / yellow LED
Connection terminal	2.5 mm ² fixed screw type
Housing material	UL94V-0 plastic material
Approx. weight	207 g (7.31 oz) 379 g (13.38 oz) 756 g (26.69 oz)
Mounting information	vertical on rail adjacent without gap

MOUNTING ACCESSORIES

Mounting rail type according to IEC60715/TH35	PR/3/AC, PR/3/AC/ZB, PR/3/AS, PR/3/AS/ZB
Mounting rail type according to IEC60715/G32	PR/DIN/AC - PR/DIN/AS - PR/DIN/AL
Replacement relay (1)	Cat. No. 8904404
Screw type jumper	—

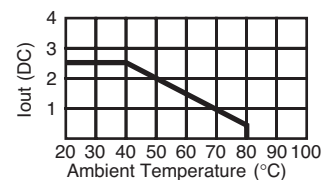

Solid state 24 Vdc relay modules with electronic protection

- Rated current output 8 x 2.5 A / 5 - 33 Vdc
- Short circuit, overload, over temperature, overvoltage output protection
- 12-24 Vdc negative common input, 8 status LED K1 and K8
- 8 output status LED, input/output anti polarity inversion diodes
- 70 mm wide

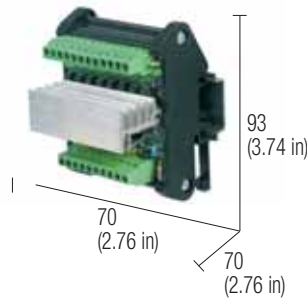

NOTES

- (1) Maximum output current of each channel depends on surrounding air temperature, on the number of output contemporarily active and on the current flowing through them; the given value is measured with 4 active outputs and 4 not active.
- (2) All outputs are overcurrent and overtemperature; when ovd or ovt protections cuts off the output current, the output display led turns off or reduce its light depending on ovd degree; the output turns on automatically when the ovd or ovt are removed.

BLOCK DIAGRAM

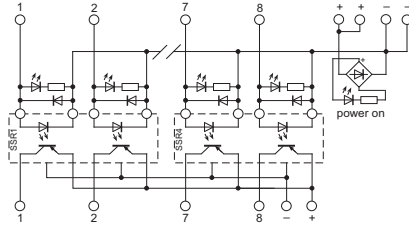

VERSIONS

4 relay module

8 relay module

16 relay module

Cat. No. XCOP082

COP082

INPUT TECHNICAL DATA

Input voltage	5-24 Vdc (range 4.2...32 Vdc) negative common
Level 1 (high) input signal	> 3.5 Vdc
Level 0 (low) input signal	< 3.5 Vdc
Rated current (1 channel)	5 mA \pm 10%
Switching frequency	500 Hz

OUTPUT TECHNICAL DATA

Output voltage	12-24 Vdc, (range 5...32 Vdc) negative common
Continuous load current	8 x 2.5 A @ 25°C (1)
Max. current	4.4 A
Leakage current 0 signal	25 μ A max @ 24Vdc
OFF/ON switching time	200 Hz (Ton < 500 μ s / Toff < 500 μ s)
Protection circuit	electronic against short circuit / overload / overtemperature (2)
Min. applicable load	5.2 Vdc/ 100 mA

GENERAL TECHNICAL DATA

Operating temperature range	-20...-60°C (with therml protection) (2)
I/O isolation	2.5 KVac / 60 s
Isolation between output terminals	1 KVac / 60 s (between open contact)
Protection degree	IP 00 IEC 529, EN60529
Overvoltage category / Pollution degree	III / 2
Reference Standard	IEC 664-1, DIN VDE 0110.1
Status display	green LED (DC OK) / yellow LED (output OK)
Connection terminal	2.5 mm ² fixed screw type
Housing material	UL94V-0 plastic material
Approx. weight	
Mounting information	vertical on rail adjacent without gap

MOUNTING ACCESSORIES

Mounting rail type according to IEC60715/TH35	PR/3/AC, PR/3/AC/ZB, PR/3/AS, PR/3/AS/ZB
Mounting rail type according to IEC60715/G32	PR/DIN/AC - PR/DIN/AS - PR/DIN/AL
Replacement relay (1)	—
Screw type jumper	—

Passive interface modules selection table

These tables allow you to quickly select only the items, then check if all product's technical data meet your application requirements.

Sub-D / Terminal modules

Version	Dimensions AxBxC	Tipology	Type	Cat. No.	Page
9 poles	37x66x93	(6)	ISD09FM	XISD09FM	142
	37x66x93	(5)	ISD09PF	XISD09PF	142
	37x66x93	(8)	ISD09PM	XISD09PM	142
15 poles	47x66x93	(6)	ISD15FM	XISD15FM	142
	47x66x93	(5)	ISD15PF	XISD15PF	142
	47x66x93	(8)	ISD15PM	XISD15PM	142
25 poles	70x66x93	(6)	ISD25FM	XISD25FM	142
	70x66x93	(5)	ISD25PF	XISD25PF	142
	70x66x93	(8)	ISD25PM	XISD25PM	142
	57x80x93	(5) (11)	CPD25F	XCPD25F	144
	57x80x93	(8) (11)	CPD25M	XCPD25M	144
37 poles	107x66x93	(6)	ISD37FM	XISD37FM	142
	107x66x93	(5)	ISD37PF	XISD37PF	142
	107x66x93	(8)	ISD37PM	XISD37PM	142
	77x80x93	(5) (11)	CPD37F	XCPD37F	144
	77x80x93	(8) (11)	CPD37M	XCPD37M	144
50 poles	92x80x93	(5) (11)	CPD50F	XCPD50F	144
	92x80x93	(8) (11)	CPD50M	XCPD50M	144

Diode-holder modules

Version	Dimensions AxBxC	Tipology	Type	Cat. No.	Page
8 diodes	25x60x76	(4)	CDM08CS	XCDM08CS	159
	45x65x93	(1)	CDM08AC	XCDM08AC	160
	45x65x93	(2)	CDM08CC	XCDM08CC	160
16 diodes	50x65x93	(4)	CDM16CS	XCDM16CS	159
	92x65x93	(1)	CDM16AC	XCDM16AC	160
	92x65x93	(2)	CDM16CC	XCDM16CC	160
24 diodes	71x65x93	(4)	CDM24CS	XCDM24CS	159
	137x65x93	(1)	CDM24AC	XCDM24AC	160
	137x65x93	(2)	CDM24CC	XCDM24CC	160
	137x65x93	(2)	CDM24CC	XCDM24CC	160

Lamp testing modules

Version	Dimensions AxBxC	Tipology	Type	Cat. No.	Page
8 diodes	45x65x93	(1)	CLT08AC	XCLT08AC	150
	45x65x93	(2)	CLT08CC	XCLT08CC	150
	45x65x93		CLP08CC	XCLP08CC	151
16 diodes	92x65x93	(1)	CLT16AC	XCLT16AC	150
	92x65x93	(2)	CLT16CC	XCLT16CC	150
	92x65x93		CLP16CC	XCLP16CC	151

Flat / Terminal modules

Version	Dimensions AxBxC	Tipology	Type	Cat. No.	Page
10 poles	42x66x93	(8)	IF10PMS	XIF10PMS	145
	42x66x93	(8) (7)	IF10PML	XIF10PML	145
14 poles	48x66x93	(8)	IF14PMS	XIF14PMS	145
	48x66x93	(8) (7)	IF14PML	XIF14PML	145
16 poles	58x66x93	(8)	IF16PMS	XIF16PMS	145
	58x66x93	(8) (7)	IF16PML	XIF16PML	145
20 poles	70x66x93	(8)	IF20PMS	XIF20PMS	145
	70x66x93	(8) (7)	IF20PML	XIF20PML	145
	47x80x93	(8) (11)	CPC20M	XCPD20M	146
26 poles	86x66x93	(8)	IF26PMS	XIF26PMS	145
	86x66x93	(8) (7)	IF26PML	XIF26PML	145
	57x80x93	(8) (11)	CPC26M	XCPD26M	146
34 poles	107x66x93	(8)	IF34PMS	XIF34PMS	145
	107x66x93	(8) (7)	IF34PML	XIF34PML	145
	70x80x93	(8) (11)	CPC34M	XCPD34M	146
40 poles	122x66x93	(8)	IF40PMS	XIF40PMS	145
	122x66x93	(8) (7)	IF40PML	XIF40PML	145
	77x80x93	(8) (11)	CPC40M	XCPD40M	146
50 poles	92x80x93	(8) (11)	CPC50M	XCPD50M	146
60 poles	107x80x93	(8) (11)	CPC60M	XCPD60M	146
64 poli	117x80x93	(8) (11)	CPC64M	XCPD64M	146

Component-holder modules

Version	Dimensions AxBxC	Tipology	Type	Cat. No.	Page
4 components	25x66x93	(9)	CCM04SF	XCCM04SF	147
8 components	25x66x93	(10)	CCM08SV	XCCM08SV	147
8 components	47x66x93	(9)	CCM08SF	XCCM08SF	147
8 components	38x66x93	(3)	CCM08CV	XCCM08CV	147
12 components	70x66x93	(9)	CCM12SV	XCCM12SV	147
16 components	47x66x93	(10)	CCM16SV	XCCM16SV	147
24 components	70x66x93	(10)	CCM24SV	XCCM24SV	147

Legenda

- (1) common anode
- (2) common cathode
- (3) with common terminal
- (4) single diode
- (5) female connector

- (6) female + male connector
- (7) with LED
- (8) male connector
- (9) single component with Faston terminals
- (10) single component with terminal blocks
- (11) compact dimensions

Passive interfaces (D-Sub/Terminals modules) ISD series

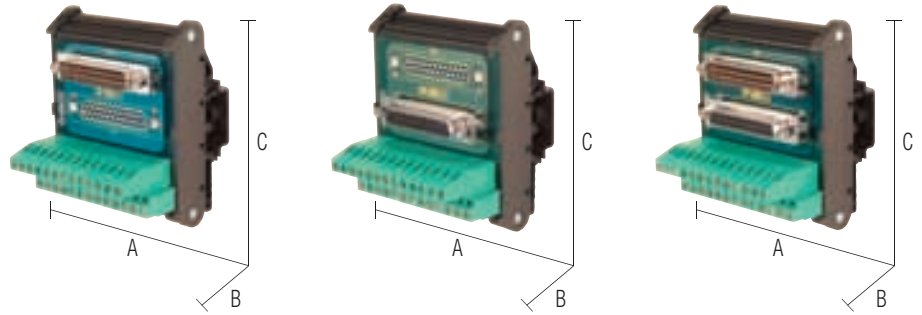

NOTES

These modules allow the transferring to the terminals of the deriving signals on a cable with D-Sub connector type. The numeration is "pin-to-pin".

BLOCK DIAGRAM

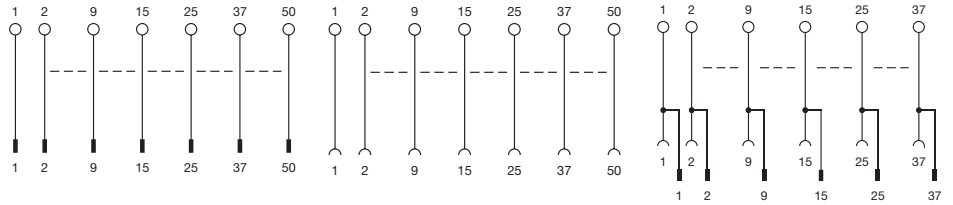

VERSIONS	DIMENSIONS (A x B x C)	male		female		male + female	
		Item	Cat. No.	Item	Cat. No.	Item	Cat. No.
9 poles	37x66x93 (1.46x2.60x3.66 in)	ISD09PM	XISD09PM	ISD09PF	XISD09PF	ISD09FM	XISD09FM
15 poles	47x66x93 (1.85x2.60x3.66 in)	ISD15PM	XISD15PM	ISD15PF	XISD15PF	ISD15FM	XISD15FM
25 poles	70x66x93 (2.76x2.60x3.66 in)	ISD25PM	XISD25PM	ISD25PF	XISD25PF	ISD25FM	XISD25FM
37 poles	107x66x93 (4.21x2.60x3.66 in)	ISD37PM	XISD37PM	ISD37PF	XISD37PF	ISD37FM	XISD37FM
GENERAL TECHNICAL DATA		0...50 Vac / 0...75 Vdc 2 A max. -20...+60°C IP00 IEC529; EN60529 IEC 664-1; DIN VDE 0110.1 2 II polyamide UL94V-0 2.5 mm ² fixed screw type (AWG 14) vertical on rail adjacent without gap		0...50 Vac / 0...75 Vdc 2 A max. -20...+60°C IP00 IEC529; EN60529 IEC 664-1; DIN VDE 0110.1 2 II polyamide UL94V-0 2.5 mm ² fixed screw type (AWG 14) vertical on rail adjacent without gap		0...50 Vac / 0...75 Vdc 2 A max. -20...+60°C IP00 IEC529; EN60529 IEC 664-1; DIN VDE 0110.1 2 II polyamide UL94V-0 2.5 mm ² fixed screw type (AWG 14) vertical on rail adjacent without gap	
MOUNTING ACCESSORIES		Mounting rail type according to IEC60715/TH35 Mounting rail type according to IEC60715/G32 Jumper bridge black					
		PR/3/AC - PR/3/AS PR/DIN/AC - PR/DIN/AS - PR/DIN/AL —					

Passive interfaces (D-Sub/Terminals modules) ISD series

- With LED to display the status

Item available till sell-out

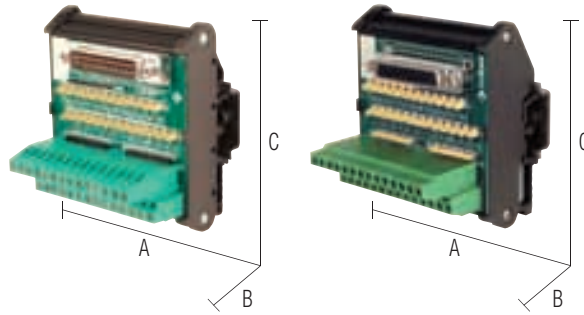

NOTES

These modules allow the transferring to the terminals of the deriving signals on a cable with D-Sub connector type

The numeration is "pin-to-pin"

(1) The LEDs are predisposed for a nominal voltage of 24 Vdc and negative common.

BLOCK DIAGRAM

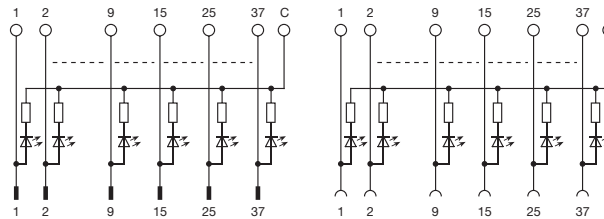

VERSIONS	DIMENSIONS (A x B x C)	male		female	
		Item	Cat. No.	Item	Cat. No.
25 poles	80x66x93 (3.15x2.60x3.66 in)	ISD25PML	XISD25PML	ISD25PFL	XISD25PFL
37 poles	109x66x93 (4.30x2.60x3.66 in)	ISD37PML	XISD37PML	ISD37PFL	XISD37PFL

GENERAL TECHNICAL DATA

Rated voltage	12...24 Vdc ±10% (1)
Rated current	2 A max.
Operating temperature	-20...+60°C
Protection degree	IP00 IEC529; EN60529
Reference Standard	IEC 664-1; DIN VDE 0110.1
Pollution degree	2
Overtoltage category	II
Housing material	polyamide UL94V-0
Connection terminal blocks	2.5 mm ² fixed screw type (AWG 14)
Mounting information	vertical on rail adjacent without gap

MOUNTING ACCESSORIES

Mounting rail type according to IEC60715/TH35	PR/3/AC - PR/3/AS
Mounting rail type according to IEC60715/G32	PR/DIN/AC - PR/DIN/AS - PR/DIN/AL
Jumper bridge	black

Passive interfaces (D-Sub/Terminals modules) CPD series

- Compact dimensions

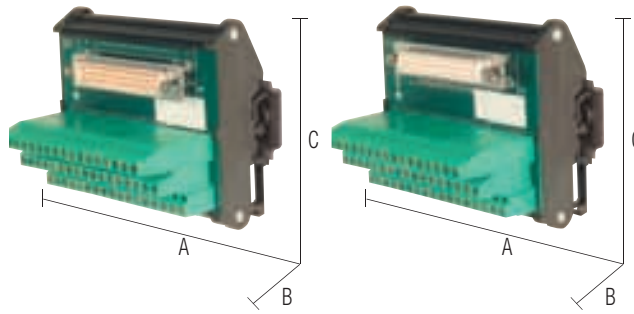

NOTES

These modules allow the transferring to the terminals of the deriving signals on a cable with D-Sub connector type.

The numeration is "pin-to-pin".
(1) Version available upon request

BLOCK DIAGRAM

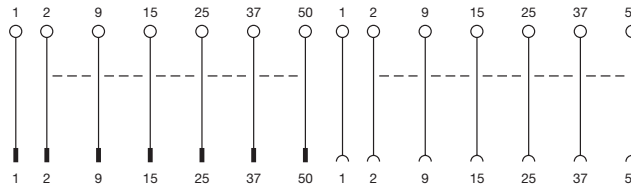

VERSIONS	DIMENSIONS (A x B x C)	male		female	
		Item	Cat. No.	Item	Cat. No.
25 poles	57x80x93 (2.24x3.15x3.66 in)	CPD25M	XCPD25M	CPD25F	XCPD25F
37 poles	77x80x93 (3.03x3.15x3.66 in)	CPD37M	XCPD37M	CPD37F	XCPD37F
50 poles	92x80x93 (3.62x3.15x3.66 in)	CPD50M	XCPD50M	CPD50F	XCPD50F

GENERAL TECHNICAL DATA

Rated voltage	0...50 Vac / 0...75 Vdc
Rated current	2 A max.
Operating temperature	-20...+60°C
Protection degree	IP00 IEC529; EN60529
Reference Standard	IEC 664-1; DIN VDE 0110.1
Pollution degree	2
Overvoltage category	II
Housing material	polyamide UL94V-0
Connection terminal blocks	2.5 mm ² fixed screw type (AWG 14)
Mounting information	vertical on rail adjacent without gap

MOUNTING ACCESSORIES

Mounting rail type according to IEC60715/TH35	PR/3/AC - PR/3/AS
Mounting rail type according to IEC60715/G32	PR/DIN/AC - PR/DIN/AS - PR/DIN/AL
Jumper bridge	black —

Passive interfaces (I.D.C./Terminal blocks) IF series

- Available with LED to display the status

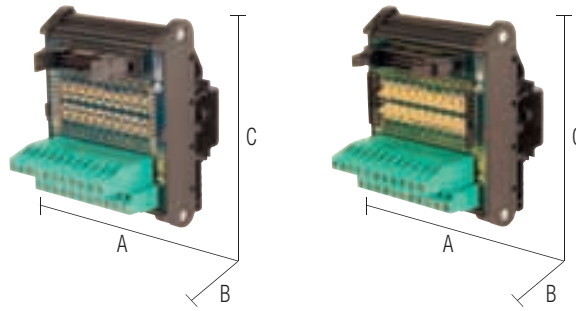

NOTES

The modules allow the transferring to the terminals the deriving signals on Flat-cable through the employment of IDC ribbon cable connectors (with insulation displacement).

The numeration is "pin-to-pin".

(1) Version available upon request

(2) The LEDs are predisposed for a nominal voltage of 24 Vdc and negative common

BLOCK DIAGRAM

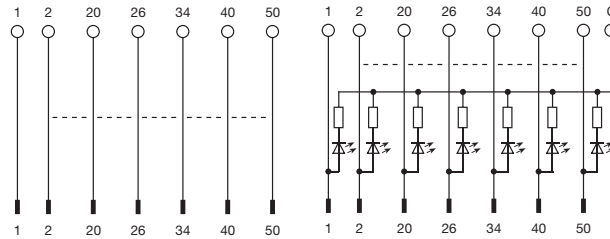

VERSIONS	DIMENSIONS (A x B x C)	Without LED		With LED	
		Item	Cat. No.	Item	Cat. No.
10 poles	42x66x93 (1.65x2.60x3.66 in)	IF10PMS (1)	XIF10PMS	IF10PML (1)	XIF10PML
14 poles	48x66x93 (1.89x2.60x3.66 in)	IF14PMS (1)	XIF14PMS	IF14PML (1)	XIF14PML
16 poles	58x66x93 (2.28x2.60x3.66 in)	IF16PMS	XIF16PMS	IF16PML	XIF16PML
20 poles	70x66x93 (2.76x2.60x3.66 in)	IF20PMS	XIF20PMS	IF20PML	XIF20PML
26 poles	86x66x93 (3.39x2.60x3.66 in)	IF26PMS	XIF26PMS	IF26PML	XIF26PML
34 poles	107x66x93 (4.21x2.60x3.66 in)	IF34PMS	XIF34PMS	IF34PML	XIF34PML
40 poles	122x66x93 (4.80x2.60x3.66 in)	IF40PMS	XIF40PMS	IF40PML	XIF40PML

GENERAL TECHNICAL DATA

Rated voltage	0...50 Vac / 0...75 Vdc	12...24 Vdc ±10% (2)
Rated current	750 mA max.	750 mA max.
Operating temperature	-20...+60°C	-20...+60°C
Protection degree	IP00 IEC529; EN60529	IP00 IEC529; EN60529
Reference Standard	IEC 664-1; DIN VDE 0110.1	IEC 664-1; DIN VDE 0110.1
Pollution degree	2	2
Overvoltage category	II	II
Housing material	polyamide UL94V-0	polyamide UL94V-0
Connection terminal blocks	2.5 mm ² fixed screw type (AWG 14)	2.5 mm ² fixed screw type (AWG 14)
Mounting information	vertical on rail adjacent without gap	vertical on rail adjacent without gap

MOUNTING ACCESSORIES

Mounting rail type according to IEC60715/TH35	PR/3/AC - PR/3/AS
Mounting rail type according to IEC60715/G32	PR/DIN/AC - PR/DIN/AS - PR/DIN/AL
Jumper bridge	black

Passive interfaces (I.D.C./Terminal blocks) CPC series

- Compact dimensions

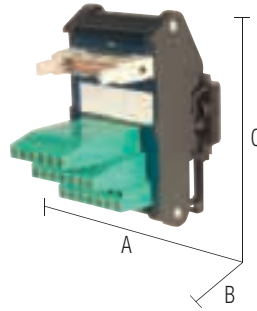

NOTES

The modules allow the transferring to the terminals of the deriving signals on Flat-cable through the employment of IDC ribbon cable connectors (with insulation displacement).
The numeration is "pin-to-pin".

BLOCK DIAGRAM

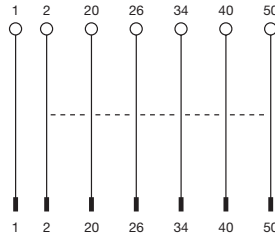

VERSIONS	DIMENSIONS (A x B x C)	without LED	
		Item	Cat. No.
20 poles	47x80x93 (1.85x3.15x3.66 in)	CPC20M	XCPC20M
26 poles	57x80x93 (2.24x3.15x3.66 in)	CPC26M	XCPC26M
34 poles	70x80x93 (2.76x3.15x3.66 in)	CPC34M	XCPC34M
40 poles	77x80x93 (3.03x3.15x3.66 in)	CPC40M	XCPC40M
50 poles	92x80x93 (3.62x3.15x3.66 in)	CPC50M	XCPC50M
60 poles	107x80x93 (4.21x3.15x3.66 in)	CPC60M	XCPC60M
64 poles	117x80x93 (4.61x3.15x3.66 in)	CPC64M	XCPC64M

GENERAL TECHNICAL DATA

Rated voltage	0...50 Vac / 0...75 Vdc
Rated current	750 mA max.
Operating temperature	-20...+60°C
Protection degree	IP00 IEC529; EN60529
Reference Standard	IEC 664-1; DIN VDE 0110.1
Pollution degree	2
Overvoltage category	II
Housing material	polyamide UL94V-0
Connection terminal blocks	2.5 mm ² fixed screw type (AWG 14)
Mounting information	vertical on rail adjacent without gap

MOUNTING ACCESSORIES

Mounting rail type according to IEC60715/TH35	PR/3/AC - PR/3/AS
Mounting rail type according to IEC60715/G32	PR/DIN/AC - PR/DIN/AS - PR/DIN/AL
Jumper bridge	black

Component-holders modules CCM series

- Compact dimensions
- Available with fast-on connection

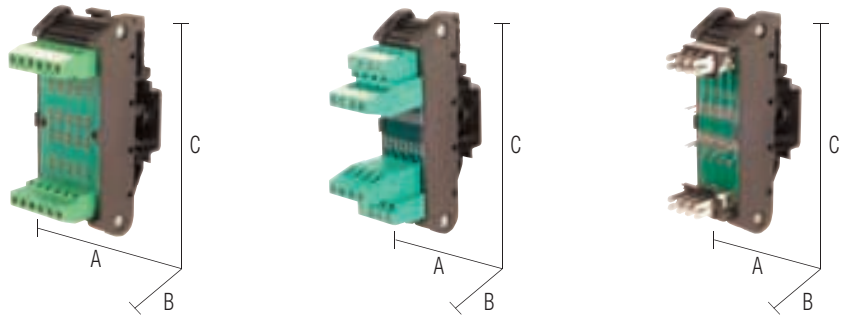

NOTES

The component-holders modules allow the montage of electronic components (diodes, resistors, capacitors etc.) according to customer needs.

They are available with connections with terminal blocks or Faston, and with holes of different diameters for the terminals of the components.

(1) Version available upon request; for info call our sales dept., local agent or representative

BLOCK DIAGRAM

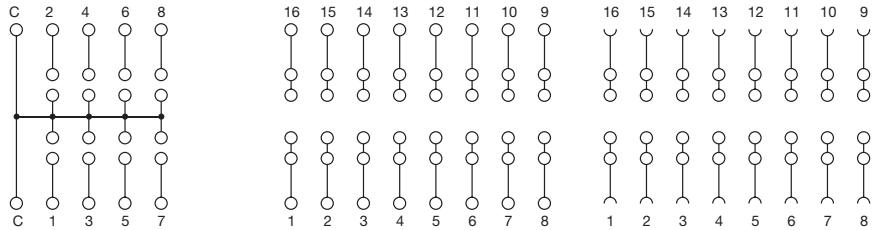

VERSIONS	DIMENSIONS (A x B x C)	with common terminal		single with terminals		single with Faston	
		Item	Cat. No.	Item	Cat. No.	Item	Cat. No.
4 components	25x66x93 (0.98x2.60x3.66 in)	—	—	—	—	CCM04SF	XCCM04SF
8 components	25x66x93 (0.98x2.60x3.66 in)	—	—	CCM08SV	XCCM08SV	—	—
8 components	47x66x93 (1.85x2.60x3.66 in)	—	—	—	—	CCM08SF	XCCM08SF
8 components	25x55x93 (0.98x2.17x3.66 in)	CCM08CV	XCCM08CV	—	—	—	—
12 components	70x66x93 (2.76x2.60x3.66 in)	—	—	—	—	CCM12SF (1)	XCCM12SF
16 components	47x66x93 (1.85x2.60x3.66 in)	CCM16CV	XCCM16CV	CCM16SV	XCCM16SV	—	—
24 components	70x66x93 (2.76x2.60x3.66 in)	—	—	CCM24SV (1)	XCCM24SV	—	—

GENERAL TECHNICAL DATA

	with common terminal	single with terminals	single with Faston
Rated voltage	0...220 V ±10%	0...100 V ±10%	0...100 V ±10%
Rated current	5 A (channel) / 15 A (common)	2 A max. (on the common)	2 A max. (on the common)
Operating temperature	-20...+60°C	-20...+60°C	-20...+60°C
Protection degree	IP00 IEC529; EN60529	IP00 IEC529; EN60529	IP00 IEC529; EN60529
Reference Standard	IEC 664-1; DIN VDE 0110.1	IEC 664-1; DIN VDE 0110.1	IEC 664-1; DIN VDE 0110.1
Pollution degree	2	2	2
Overvoltage category	II	II	II
Housing material	polyamide UL94V-0	polyamide UL94V-0	polyamide UL94V-0
Connection terminal blocks	2.5 mm ² fixed screw type (AWG 14)	2.5 mm ² fixed screw type (AWG 14)	2.5 mm ² fixed screw type (AWG 14)
Mounting information	vertical on rail adjacent without gap	vertical on rail adjacent without gap	vertical on rail adjacent without gap

MOUNTING ACCESSORIES

Mounting rail type according to IEC60715/TH35	PR/3/AC - PR/3/AS
Mounting rail type according to IEC60715/G32	PR/DIN/AC - PR/DIN/AS - PR/DIN/AL
Jumper bridge	black

The PMC series has changed its Cat. No. into CCM series, these are the cross reference list.

Old item	New item
PMC0001	CCM08CV
PMC0002	CCM08SV
PMC0003	CCM16SV
PMC0004	CCM24SV
PMC0005	CCM04SF
PMC0006	CCM08SF
PMC0007	CCM12SF

Diode-holder modules with single diodes CDM series

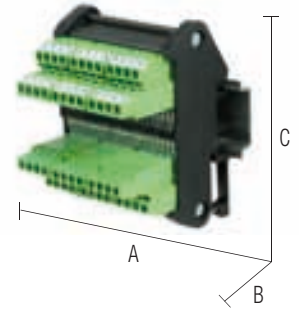
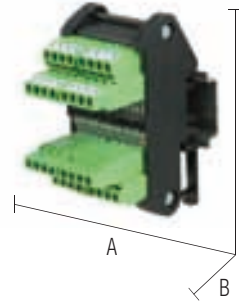
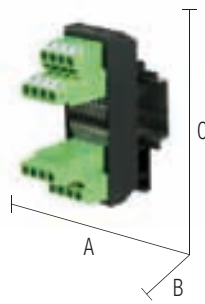

NOTES

BLOCK DIAGRAM

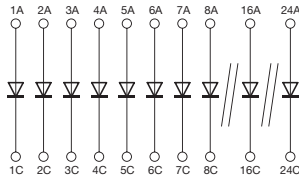

VERSIONS	DIMENSIONS (A x B x C)	single diode	
		Item	Cat. No.
8 diodes	25x60x76 (0.98x2.36x3.66 in)	CDM08CS	XCDM08CS
16 diodes	50x65x93 (1.97x2.56x3.66 in)	CDM16CS	XCDM16CS
24 diodes	71x65x93 (2.80x2.56x3.66 in)	CDM24CS	XCDM24CS

GENERAL TECHNICAL DATA	
Rated voltage	0...100 V ±10%
Rated current	1 A max.
Diode type	1N4007
Repetitive peak reverse voltage	1000 V
Operating temperature	-20...+60°C
Protection degree	IP00 IEC529; EN60529
Reference Standard	IEC 664-1; DIN VDE 0110.1
Pollution degree	2
Overvoltage category	II
Housing material	polyamide UL94V-0
Connection terminal blocks	2.5 mm ² fixed screw type (AWG 14)
Mounting information	vertical on rail adjacent without gap

MOUNTING ACCESSORIES	
Mounting rail type according to IEC60715/TH35	PR/3/AC - PR/3/AS
Mounting rail type according to IEC60715/G32	PR/DIN/AC - PR/DIN/AS - PR/DIN/AL
Jumper bridge	black —

Diode-holder modules with common terminal CDM series

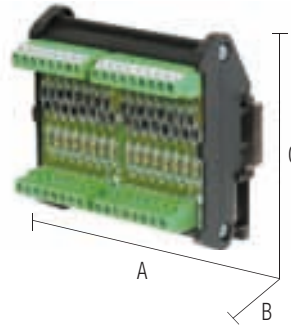

NOTES

BLOCK DIAGRAM

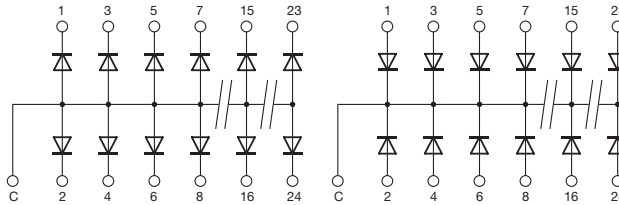

VERSIONS	DIMENSIONS (A x B x C)	common anode		common cathode	
		Item	Cat. No.	Item	Cat. No.
8 diodes	45x65x93 (1.77x2.56x3.66 in)	CDM08AC	XCDM08AC	CDM08CC	XCDM08CC
16 diodes	92x65x93 (3.62x2.56x3.66 in)	CDM16AC	XCDM16AC	CDM16CC	XCDM16CC
24 diodes	137x65x93 (5.39x2.56x3.66 in)	CDM24AC	XCDM24AC	CDM24CC	XCDM24CC

GENERAL TECHNICAL DATA

Rated voltage	0...230 V ±10%
Rated current	1 A (channel) / 15 A (common).
Operating temperature	1N4007
Diode type	1000 V
Repetitive peak reverse voltage	-20...+60°C
Protection degree	IP00 IEC529; EN60529
Reference Standard	IEC 664-1; DIN VDE 0110.1
Pollution degree	2
Overvoltage category	II
Housing material	polyamide UL94V-0
Connection terminal blocks	2.5 mm ² fixed screw type (AWG 14)
Mounting information	vertical on rail adjacent without gap

MOUNTING ACCESSORIES

Mounting rail type according to IEC60715/TH35	PR/3/AC - PR/3/AS
Mounting rail type according to IEC60715/G32	PR/DIN/AC - PR/DIN/AS - PR/DIN/AL
Jumper bridge	black

LED testing modules CLT series

- Compact dimensions
- Integrated limitation resistance
- Suitable only for LED without resistance limiter
- Not suitable for LED lamp with internal limiter circuit

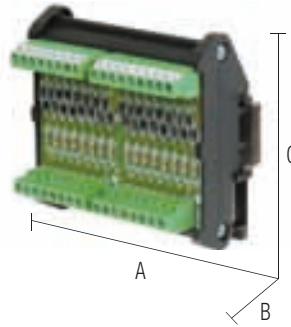

NOTES

- (1) Led test can be performed through a negative signal on the common output
- (2) Led test can be performed through a positive signal on the common input

BLOCK DIAGRAM

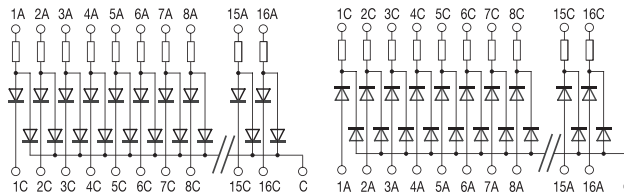

VERSIONS	DIMENSIONS (A x B x C)	common negative (1)		common positive (2)	
		Item	Cat. No.	Item	Cat. No.
8 channels	45x65x93 (1.77x2.56x3.66 in)	CLT08AC	XCLT08AC	CLT08CC	XCLT08CC
16 channels	92x65x93 (3.62x2.56x3.66 in)	CLT16AC	XCLT16AC	CLT16CC	XCLT16CC

GENERAL TECHNICAL DATA

Rated voltage	24 Vdc max. 30 Vdc
Rated current (1 channel)	5 mA @ 24 Vdc
Diode type	1N4007
Limitation resistance	4,7 KΩ 1/4 W ±5%
Repetitive peak reverse voltage	1000 V
Operating temperature	-20...+45°C
Housing material	polyamide UL94V-0
Protection degree	IP 00 IEC529, EN60529
Connection terminal blocks	2.5 mm ² fixed screw type
Mounting information	vertical on rail adjacent without gap

MOUNTING ACCESSORIES

Mounting rail type according to IEC60715/TH35	PR/3/AC – PR/3/AC/ZB – PR/3/AS – PR/3/AS/ZB
Mounting rail type according to IEC60715/G32	PR/DIN/AC - PR/DIN/AS - PR/DIN/AL
Jumper bridge	black

Lamp testing modules CLP series

- Compact dimensions
- Suitable also for LED lamp with resistance limiter

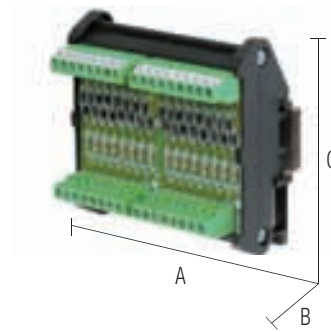

NOTES

With AC input, the diodes rectify the current and the power will be halved.

- (1) Led test can be performed through a negative signal on the common output
- (2) Led test can be performed through a positive signal on the common input

BLOCK DIAGRAM

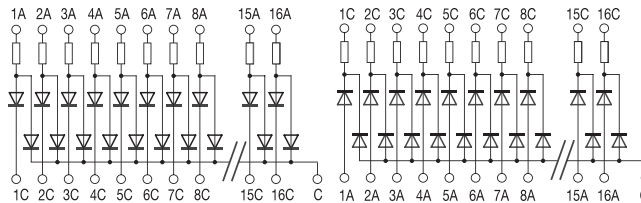

VERSIONS	DIMENSIONS (A x B x C)	common negative (1)		common positive (2)	
		Item	Cat. No.	Item	Cat. No.
8 channels	45x65x93 (1.77x2.56x3.66 in)			CLP08CC	XCLP08CC
16 channels	92x65x93 (3.62x2.56x3.66 in)			CLP16CC	XCLP16CC

GENERAL TECHNICAL DATA

Rated voltage	230 Vac/dc
Rated current (1 channel)	100 mA @ 120 Vac/dc; 50 mA @ 230 Vac/dc
Diode type	1N4007
Limitation resistance	0
Repetitive peak reverse voltage	700 V
Operating temperature	-20...+45°C
Housing material	polyamide UL94V-0
Protection degree	IP 00 IEC529, EN60529
Connection terminal blocks	2.5 mm ² fixed screw type
Mounting information	vertical on rail adjacent without gap

MOUNTING ACCESSORIES

Mounting rail type according to IEC60715/TH35	PR/3/AC – PR/3/AC/ZB – PR/3/AS – PR/3/AS/ZB
Mounting rail type according to IEC60715/G32	PR/DIN/AC - PR/DIN/AS - PR/DIN/AL
Jumper bridge	black

Housing for custom applications CH series

• Available on 3 measures

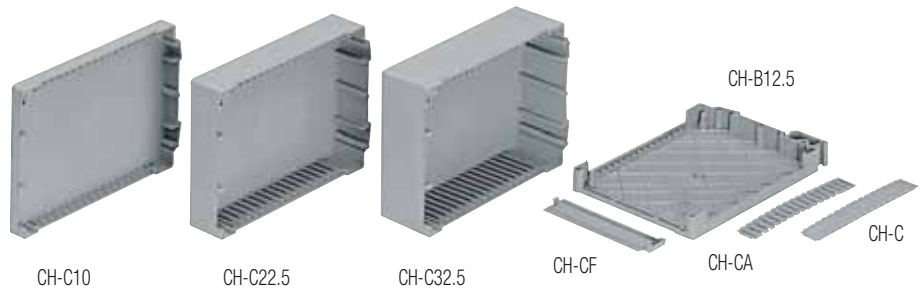

NOTES

(1) Maximum height of the components measured between the circuit and the cover

BLOCK DIAGRAM

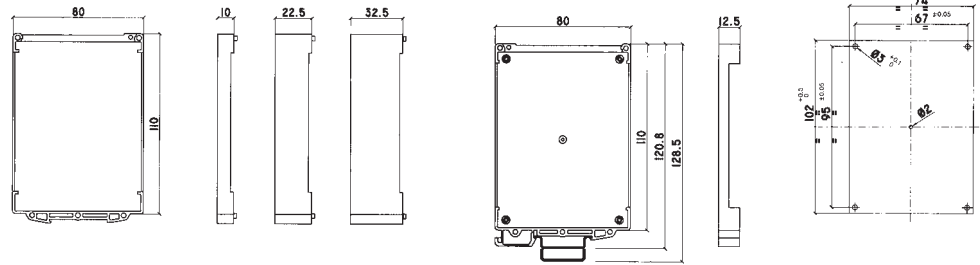

VERSIONS

Right side with hook for DIN rail, 12.5 mm
Left side housing, 10 mm
Left side housing, 22.5 mm
Left side housing, 32.5 mm
Openable hinged cover
Vented cover
Enclosed cover
fixed hinged cover

Item

Cat. No.

CH-B12.5	XBB125
CH-C10	XBC010
CH-C22.5	XBC225
CH-C32.5	XBC325
CH-S	XBS000
CH-CA	XBCA00
CH-C	XBC000
CH-CF	XBCF00

APPLICATIONS

CH electronic housings

With the CH (Cabur Housing) series containers, Cabur proposes a modular system which allows you to obtain boxes with 3 width sizes 22.5 mm - 35 mm - 45 mm - composed by 8 easy-to-assemble parts.

The circuit can have a maximum size of 102 x 74 mm and can be inserted on 4 small columns formed in the base which holds it in position.

Additional anchorage of the circuit is possible with a 2.2 x 4.5 mm self-threading screw to be screwed into the central column, also allowing small circuit to be mounted.

The conductors are connected with 2.5 mm pluggable terminals, which are readily available.

16 connection poles which can be used with pitch of 5.08 on each side and 10 on the front side.

The CH-S front closure, with panel opening, provides access to the internal circuit for work on the potentiometers, jumpers and micro-switches.

The side covers are available with ventilating holes or closed, and are pre-cutted with 5.08 mm pitch, to make possible an easy cut into necessary length with a pair of scissors, for an easy fit to final dimensions.

The following are required for a composition of a housing::

- 1 CH-B12.5 base 12.5 mm wide
- 1 cover (3 sizes available)

CH-C10	10 mm wide
CH-C22.5	22.5 mm wide
CH-C32.5	32.5 mm wide

(by adding together the width of the base 12.5 mm with the width of the cover chosen from the 4 available, the total width of the housing is obtained)

- 1 front closure in two versions:

CH-S	with panel opening
CH-CF	fixed

- 2 side closures in two versions:

CH-C	without vents
CH-CA	with vents

GENERAL TECHNICAL DATA

Material	Poliamide UL94V-0
Colour	RAL 5014
Temperature	max 80 °C
Dissipated power	max 7 W
Protection degree	fino a IP30
Number of poles for every side	16 +16 (5.08)
Number of poles on the top	10 (5.08)
Mounting information	

MOUNTING ACCESSORIES

Mounting rail type according to IEC60715/TH35-7.5	PR/3/AC, PR/3/AS
Mounting rail type according to IEC60715/G32	—
Jumper bridge	—
red	—
white	—
blue	—

Interior height max (1)	CH-B12.5	CH-C10	CH-C22.5	CH-C32.5	CH-S	CH-CA CH-C
19.1 mm	1	1			1	2
31.6 mm	1		1		1	2
41.6 mm	1			1	1	2

Housing for custom applications CK series

- 6 mm wide, expandable modules
- 6 spring-clamp 2,5 mm² / AWG 26 ÷ 14 terminal blocks
- Jumper insertion possibility on each of the 4 levels
- Hinged front cover access to the printed circuit board

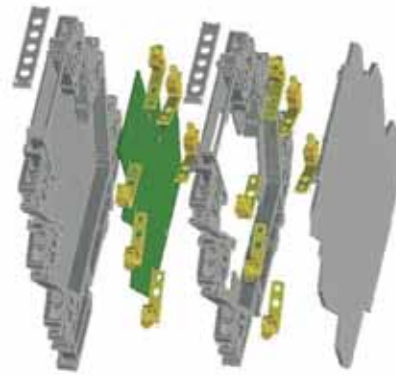

NOTES

- (1) 6 spring-clamp terminal blocks included with solder contact
- (2) In order to assure the IP20 protection degree, the last module must be protected and insulated using the CK/PT end section

BLOCK DIAGRAM

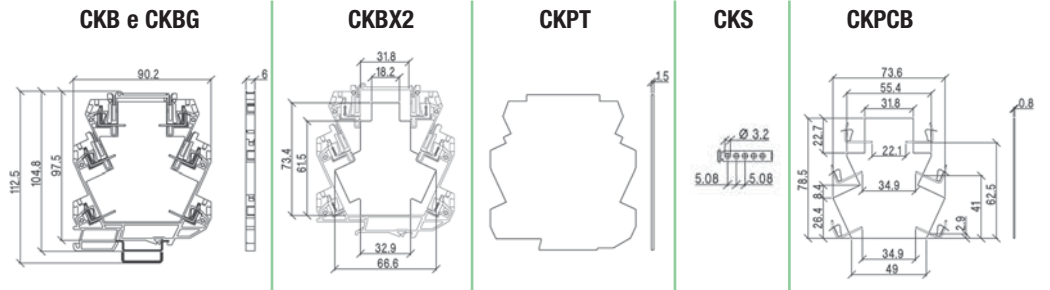

VERSIONS

Standard base
Base element with ground contact
Expansion module
End section
Front hinge cover
Printed circuit board

Item	Cat. No.
CKB (1)	XCKB
CKBG (1)	XCKBG
CKBX2 (1)	XCKX2
CK/PT	XCKPT
CK/S	XCKS
CK/PCB	8901028

APPLICATIONS

With the CK series modular housings, Cabur offers a modular system that provides housings with increasing dimensions in width for simple components as diodes, resistors or more complex circuits with or without the support of a printed circuit board. For the composition of an housing the following items are necessary:

- a base support element, available in two versions: CKB and CKBG; the latter is provided with an electric metal contact on the DIN rail that allows to connect the internal circuit to the ground. Ground contact towards the DIN rail can carry an impulsive current value of 5 KA (8/20 peak). Both models have an external width of 6 mm and internal width of 5 mm; they are also equipped with 6 springclamp terminal blocks and 4 slots for the insertion of a jumper;
- one or more CKBX2 type expansion modules similar to the base support element, having therefore an external width of 6 mm and a central slot that allows the housing of the bulky components with a height exceeding the overall height of the base support element; the expansion module is also equipped with 6 spring-clamp terminal blocks and 4 slots for the insertion of a jumper;
- the CK/S front cover, granting access to the interior of the product, is also available. Once in open position it has such a dimension in order to guarantee a IPXXB degree of protection, even when it is not employed;
- in order to assure the IPXXB protection degree, the last module must be protected and insulated using the CK/PT end section;
- the CK/PCB printed circuit board is also available; it is useful in low volume custom applications where a special pcb is not designed and also where one requires a prototype without tooling a special printed circuit board.

GENERAL TECHNICAL DATA

Rated voltage of each terminal block
Rated current of each terminal block
Operating temperature
Protection degree (2)
Connection terminals
Housing material
Approx. weight
Parallel bridge
Marking tags

230 Vac/dc ± 10%
≤ 24 A
-40...+ 100°C
IP20 IEC529 EN60529
2.5 mm ² , AWG26-14 spring type
polyamide UL 94V0
20 g (CKB, CKBG), 15 g (CKX2, CK/PT) 20 g (CK/PT), 1 g (CK/S), 5 g (CK/PCB)
PTC/CK/42 Cat. No. PTCC42 (42 poli)
CNU/8/030 Cat. No. NU0851

MOUNTING INFORMATION

on rail

MOUNTING ACCESSORIES

Mounting rail type according to IEC60715/TH35-7.5
Mounting rail type according to IEC60715/G32
Jumper bridge

PR/3/AC, PR/3/AC/ZB, PR/3/AS, PR/3/AS/ZB
—
—
—

Ground contact on CKBG



CKBX2



CKB



CK/PCB

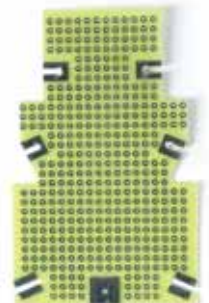

Plug-in jumper for CK series

Notes:

- (1) Example of a pre-cut 9 position jumper
- (2) CK/PT end section must be mounted on last module to assure IP20 protection degree
- (3) 32 A is the maximum current; however this value is limited by the rated current of the spring-clamp terminal blocks down to 24 A; for instance, having a jumper of 11 poles (1 for common and 10 for distribution) a current of 2.4 A can be distributed on every poles



VERSIONS	Item	Cat. No.
	PTC/CK/42	PTCCK42
GENERAL TECHNICAL DATA		
Protection degree (2)	IP20 IEC529; EN60529	
Number of poles	42	
Pitch	6 mm (0.24 in)	
Rated current carrying capacity of jumper (3)	32 A	
Insulation color	—	
Material	tin copper alloy	
Approx. weight	27 g (0.95 oz) (42 poles)	

Plug-in jumper for CW..7 series



VERSIONS	Item	Cat. No.	Item	Cat. No.	Item	Cat. No.
	CWBK 7-0802	X766802	CWBK 7-0803	X766803	CWBK 7-0804	X766804
GENERAL TECHNICAL DATA						
Protection degree	IP20 IEC529; EN60529		IP20 IEC529; EN60529		IP20 IEC529; EN60529	
Number of poles	16		16		16	
Pitch	6.2 mm (2.44 in)		6.2 mm (2.44 in)		6.2 mm (2.44 in)	
Rated current carrying capacity of jumper	16 A		16 A		16 A	
Insulation color	red		white		blue	
Material	—		—		—	
Approx. weight	4 g (0.14 oz)		4 g (0.14 oz)		4 g (0.14 oz)	

Plug-in jumper for CWRE series



VERSIONS	Item	Cat. No.
	CWBK 7-0813	X766813
GENERAL TECHNICAL DATA		
Protection degree	IP20 IEC529; EN60529	
Number of poles	20	
Pitch	6.2 mm (2.44 in)	
Rated current carrying capacity of jumper	16 A	
Insulation color	blue	
Material	—	
Approx. weight	6 g (0.21 oz)	

Screw type jumper for CM series



VERSIONS	Item	Cat. No.	Item	Cat. No.
	CMB16B	XCMB16B	CMB27B	XCMB27B

GENERAL TECHNICAL DATA				
Protection degree	IP20 IEC529; EN60529		IP20 IEC529; EN60529	
Number of poles	8		8	
Pitch	16 mm (0.63 in)		27 mm (1.06 in)	
Rated current carrying capacity of jumper	16 A		16 A	
Insulation color	black		black	
Material	—		—	
Approx. weight	3 g (0.10 oz)		3 g (0.10 oz)	

Marking systems

Note:

White polycarbonate marking tags to number the terminal blocks of the CK Series modules and CWRE Series converters. To be directly inserted in dedicated holders before or after terminal board preparation.

They come in packages of 15 modules of 100 marking tags each, for a total of 1,500 marking tags.

The table shows only blank marking tags, available in packages of 1,500 pieces each, which can be written on manually using special pens or printed using an industrial marking system. In particular, **the marking tags shown here can be printed using the innovative CaburJet system and with the CaburPlot plotter.**

In addition to blank marking tags, CNU/8/51 preprinted marking tags are also available with alpha-numeric characters and with the most common electrical symbols.

For more information, please consult the Industrial Marking Systems catalogue.

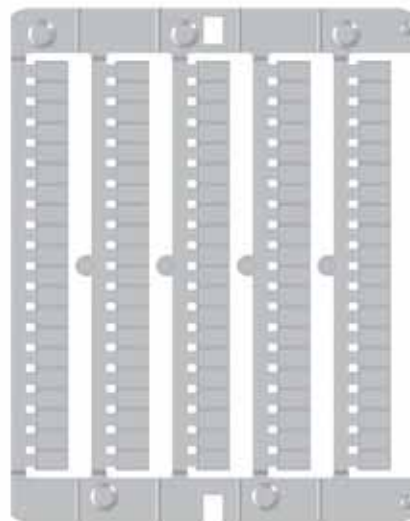

Type **CNU/8/51** code NU0851

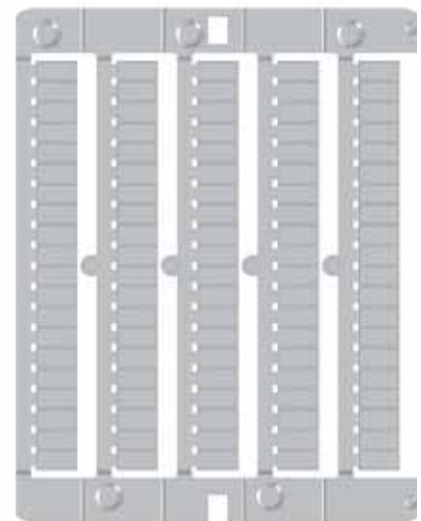

Type **NUPUTUK50** code NUPUTUK50

Description	Sigle	Code
Marking tags for marking CK Series modules	CNU/8/51	NU0851
Marking tags for marking CWRE Series converters	NUPUTUK50	NUPUTUK50

DIN rail clamp



DIMENSION

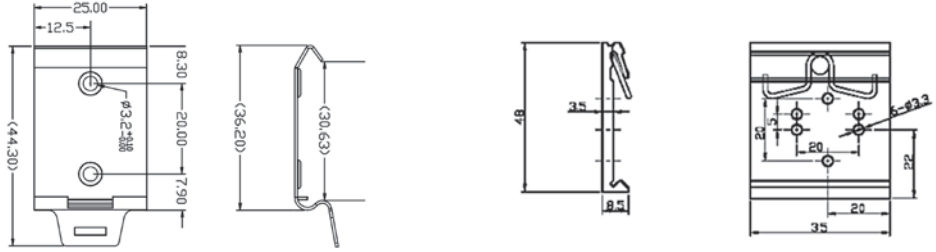

VERSIONS	Item	Cat. No.	Item	Cat. No.
	CDIN-2	XCDIN2	CDIN-4	XCDIN4

GENERAL TECHNICAL DATA

Type of material	P13-FE00		aluminium	
Treatment	black passivated		—	
Mounting information	screws or rivets		screws or rivets	
Mounting rail type according to IEC60715/TH35-7.5	PR/3/AC, PR/3/AC/ZB, PR/3/AS, PR/3/AS/ZB		PR/3/AC, PR/3/AC/ZB, PR/3/AS, PR/3/AS/ZB	
Mounting rail type according to IEC60715/G32	—		—	



DIMENSION

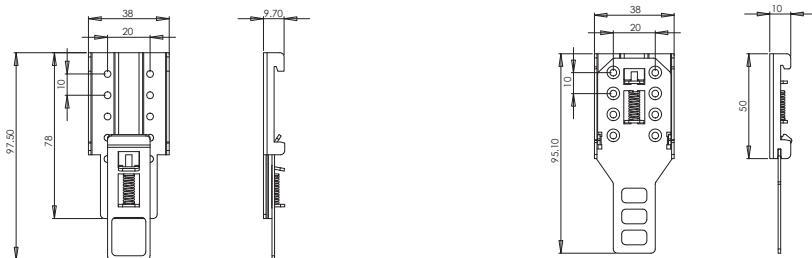

VERSIONS	Item	Cat. No.	Item	Cat. No.
	CDIN-5	XCDIN5	CDIN-M	XCDINM45

GENERAL TECHNICAL DATA

Type of material	P13-FE00		P13-FE00	
Treatment	white zinc-plated		zinc-plated	
Mounting information	screws or rivets		screws	
Mounting rail type according to IEC60715/TH35-7.5	PR/3/AC, PR/3/AC/ZB, PR/3/AS, PR/3/AS/ZB		PR/3/AC, PR/3/AC/ZB, PR/3/AS, PR/3/AS/ZB	
Mounting rail type according to IEC60715/G32	—		—	

Mounting rails

- according to IEC 60715/TH35 - 7,5
- according to IEC 60715/TH35 - 15
- supports for TH/35 type rail



DESCRIPTION	TYPE / CAT. NO.	BLOCK DIAGRAMS
IEC 60715/TH35 - 7.5 rail of passivated steel	PR/3/AC Cat. No. PR003	
IEC 60715/TH35 - 7.5 rail of white zinc-plated steel "SENDZMIR" system	PR/3/AC/ZB Cat. No. PR903	
IEC 60715/TH35 - 7.5 rail of passivated steel with slots	PR/3/AS Cat. No. PR005	
IEC 60715/TH35 - 7.5 rail of white zinc-plated steel "SENDZMIR" system with slots	PR/3/AS/ZB Cat. No. PR905	
IEC 60715/TH35 - 15 rail of passivated steel	PR/3/PP Cat. No. PR007	
IEC 60715/TH35 - 15 rail of white zinc-plated steel "SENDZMIR" system	PR/3/PP/ZB Cat. No. PR907	
IEC 60715/TH35 - 15 rail of passivated steel with slots	PR/3/PA Cat. No. PR006	
IEC 60715/TH35 - 15 rail of white zinc-plated steel "SENDZMIR" system with slots	PR/3/PA/ZB Cat. No. PR906	
Support for IEC 60715/TH35 rail of nickel plated steel and with rapid mounting system 4 MA	ACI121017 Cat. No. Z121017	
Support for IEC 60715/TH35 rail of nickel plated steel and with rapid mounting system 5 MA	ACI121019 Cat. No. Z121019	

Mounting rails

- according to IEC 60715 “G32” type rail
- according to IEC 60715/TH15 - 5.5

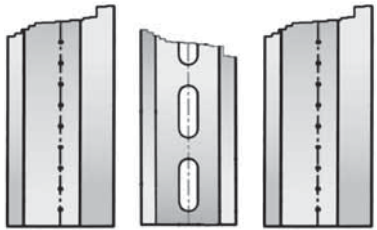
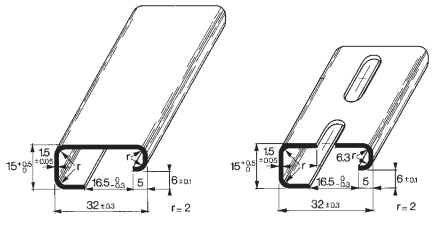
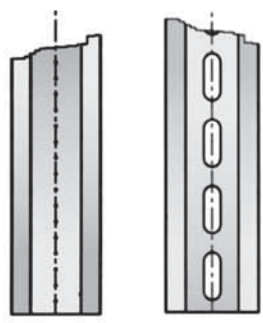
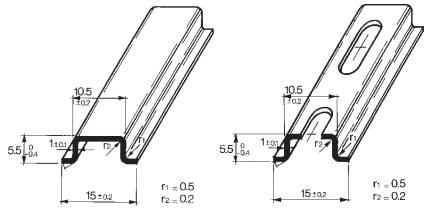

DESCRIPTION	TYPE / CAT. NO.	IMAGES
IEC 60715 “G32” type rail of passivated steel	PR/DIN/AC Cat. No. PR001	
IEC 60715 “G32” type rail of white zinc-plated steel “SENDZMIR” system	PR/DIN/AC/ZB Cat. No. PR901	
IEC 60715 “G32” type rail of passivated steel with slots	PR/DIN/AS Cat. No. PR004	
IEC 60715 “G32” type rail of white zinc-plated steel “SENDZMIR” system with slots	PR/DIN/AS/ZB Cat. No. PR904	
IEC 60715 “G32” type rail of aluminium	PR/DIN/AL Cat. No. PR002	
IEC 60715/TH15 – 5.5 rail of passivated steel	PR/2/AC Cat. No. PR009	
IEC 60715/TH15 – 5.5 rail of white zinc-plated steel “SENDZMIR” system	PR/2/AC/ZB Cat. No. PR909	
IEC 60715/TH15 – 5.5 rail of passivated steel with slots	PR/2/AS Cat. No. PR010	
IEC 60715/TH15 – 5.5 rail of white zinc-plated steel “SENDZMIR” system with slots	PR/2/AS/ZB Cat. No. PR910	

Alphabetical index

TYPE	PAGE	TYPE	PAGE	TYPE	PAGE	TYPE	PAGE
ACI121017	157	CPC20M	146	CWAA7-0532	84	LCONZBUSB	88
ACI121019	157	CPC26M	146	CWAA7-0533	85	MBC2K	60
AR1	54	CPC34M	146	CWAA7-0534	85	NUPUTUK50	155
AR6	54	CPC40M	146	CWAA7-0535	85	O332060	130
BATT112V1,2AH	57	CPC50M	146	CWAA7-0536	86	O332240	130
BY7-40/1-275	62	CPC60M	146	CWAA7-0537	86	PR/2/AC	158
BY7-40/1-440	62	CPC64M	146	CWAA7-0538	86	PR/2/AC/ZB	158
BY7-NPE/40-275	62	CPD25F	144	CWBK7-0802	154	PR/2/AS	158
BY7-NPE/40-440	62	CPD25M	144	CWBK7-0803	154	PR/2/AS/ZB	158
CAPIPO3	81	CPD37F	144	CWBK7-0804	154	PR/3/AC	157
CCIS2	93	CPD37M	144	CWBK7-0813	154	PR/3/AC/ZB	157
CCM04SF	147	CPD50F	144	CWCV7-6184	98	PR/3/AS	157
CCM08CV	147	CPD50M	144	CWNAA6-0510	83	PR/3/AS/ZB	157
CCM08SF	147	CR4-1	122	CWNAA7-0539	83	PR/3/PA	157
CCM08SV	147	CR4-2SC	123	CWNFA6-0524	97	PR/3/PA/ZB	157
CCM12SF	147	CR8-1	122	CWOT6-2082	136	PR/3/PP	157
CCM16CV	147	CR8-3	126	CWOT6-2083	135	PR/3/PP/ZB	157
CCM16SV	147	CRE4-1	122	CWPAA7-0526	87	PR/DIN/AC	158
CCM24SV	147	CRE4-2SC	123	CWPAA7-0527	87	PR/DIN/AC/ZB	158
CDIN-2	156	CRE8-1	122	CWPT6-0816	91	PR/DIN/AL	158
CDIN-4	156	CRE8-3	126	CWPT6-0817	91	PR/DIN/AS	158
CDIN-5	156	CSA120BC	48	CWRE7-0842	110	PR/DIN/AS/ZB	158
CDINM45	156	CSA120BD	48	CWRE7-0845	110	PTC/CK/42	154
CDM08AC	149	CSA120CB	48	CWRE7-0846	110	R161E11A	120
CDM08CC	149	CSA120CC	48	CWRE7-0847	110	R161E22A	121
CDM08CS	148	CSA120DB	49	CWRE7-0848	110	R161E24	112
CDM16AC	149	CSA120DC	49	CWTH6-0844	92	R161E24P	113
CDM16CC	149	CSA240FC	50	CWTH6-0847	92	R161EAD	114
CDM16CS	148	CSB150C	41	CWJAA6-0516	82	R161S24F	139
CDM24AC	149	CSB85C	40	CWJAA6-0517	82	R161U24F	115
CDM24CC	149	CSBC	55	F03DKBG5B	74	R162E24	116
CDM24CS	148	CSBD	59	F03DPCG5C	75	R162E24P	117
CEP-BCB	65	CSBP30Y	57	F06DKBG5B	74	R162EAD	118
CEP-BCR	65	CSC120B	58	F06DPCG5C	75	R162S24	137
CEP-D1	65	CSC120C	58	F07TDVST2	68	R162T24	138
CEP-D2	65	CSD15B	17	F100TDVST2	68	R41E11A	120
CEP-D3	65	CSD15C	17	F100TYT2	72	R41E22A	121
CEP-MTW	65	CSD30C	18	F10TYG9	73	R41E24	112
CEP-RCC	65	CSD30E	18	F12DKBG5B	74	R41E24P	113
CEP-RCP	65	CSD30F	18	F12DPCG5C	75	R41EAD	114
CEP-SS	65	CSD50B	19	F150TDS84C	69	R41S24F	139
CH-B12,5	152	CSD70C	20	F16DKCG5B	74	R41U24F	115
CH-C	152	CSE10	52	F16DPCG5C	75	R42E24	116
CH-C10	152	CSE3	51	F16TDVST2	68	R42E24P	117
CH-C22,5	152	CSE5	51	F16TYT2	72	R42EAD	118
CH-C32,5	152	CSF120B	24	F180TDS84C	69	R42S24	137
CH-CA	152	CSF120C	24	F200TDDS84C	70	R42T24	138
CH-CF	152	CSF120CP	24	F20DKCG5B	74	R81E11A	120
CH-S	152	CSF120DP	24	F20DPCG5C	75	R81E22A	121
CH-NPN/PNP	99	CSF240B	25	F20TYS9	73	R81E24	112
CK/PT	153	CSF240C	25	F25TYT2	72	R81E24P	113
CK/S	153	CSF240CP	25	F300TDS84C	71	R81EAD	114
CKB	153	CSF240DP	25	F30DKCS5B	74	R81S24F	139
CKBG	153	CSF240G	26	F30DPCG5C	75	R81U24F	115
CKBX2	153	CSF30B	22	F30TDVST2	68	R82E24	116
CK-PCB	153	CSF30C	22	F36TYT2	72	R82E24P	117
CKR16	109	CSF500C	27	F400TDS84C	71	R82EAD	118
CKR25	109	CSF500D	27	F42TDVST2	68	R82S24	137
CKS15E	134	CSF500G	28	F50TYT2	72	R82T24	138
CKS15NA	133	CSF5-65	29	F55TDVST2	68	RE1024D	101
CKS15NB	133	CSF85B	23	F75TDVST2	68	RE1824D	101
CKS1S	136	CSF85C	23	IF10PML	145	RE2024D	102
CKS22	134	CSF85CP	23	IF10PMS	145	RF1012D	102
CL1R	53	CSG2401C	46	IF14PML	145	RF1024D	101
CL5R	53	CSG2401D	46	IF14PMS	145	RF1824D	101
CLP08CC	151	CSG2401G	47	IF16PML	145	RFA024D	101
CLP16CC	151	CSG2401R	47	IF16PMS	145	RFE16124	128
CLT08AC	150	CSG240C	42	IF16S7	125	RFE16224	128
CLT08CC	150	CSG500C	43	IF20PML	145	RFE8124	126
CLT16AC	150	CSG500D	43	IF20PMS	145	RFE8224	127
CLT16CC	150	CSG500G	43	IF26PML	145	RMP081CM	120
CM1A012	106	CSG720C	44	IF26PMS	145	SW01VA	95
CM1A024	106	CSG720D	44	IF34PML	145	SW05VA	95
CM1A120	106	CSG960C	45	IF34PMS	145	SW10VA	95
CM1A230	106	CSG960D	45	IF40PML	145	SW20VA	96
CM1C012	103	CSG960G	45	IF40PMS	145	SW50VA	96
CM1C024	103	CSL120C	32	IF416LS7	125	WAA7-0540	94
CM1C048	103	CSL240C	33	IF416S7	125	WAA7-0541	94
CM1C110	103	CSL85C	31	ISD09FM	142	WAA7-0542	94
CM1S024	131	CSP120C	32	ISD09PF	142		
CM1S024E	131	CSP240C	33	ISD09PM	142		
CM1T024	132	CSP85C	31	ISD15FM	142		
CM1T024E	132	CS-UPS1	56	ISD15PF	142		
CM2A012	106	CS-UPS2	56	ISD15PM	142		
CM2A024	107	CSW120B	35	ISD25FM	142		
CM2A120	107	CSW120C	35	ISD25PF	142		
CM2A230	107	CSW121B	36	ISD25PFL	143		
CM2C012	104	CSW121C	36	ISD25PM	142		
CM2C024	104	CSW121DP	36	ISD25PML	143		
CM2C048	104	CSW240C	37	ISD37FM	142		
CM2C110	104	CSW240D	37	ISD37PF	142		
CM4C012	105	CSW241B	38	ISD37PFL	143		
CM4C024	105	CSW241C	38	ISD37PM	142		
CMB16B	155	CSW241DP	38	ISD37PML	143		
CMB27B	155	CSW241G	38	LCONALSFD	88		
CNU/8/51	155	CWAA7-0530	84	LCONTADFDT	89		
COP082	140	CWAA7-0531	84	LCONTLSFD	90		

Index by Catalogue number

CODE	PAGE	CODE	PAGE	CODE	PAGE	CODE	PAGE
8901028	153	XCDM24CS	148	XCSE10	52	XIF40PML	145
8911012	57	XCEPBCB	65	XCSE3	51	XIF40PMS	145
ISPD1425G	62	XCEPBCR	65	XCSE5	51	XIF416LS7	125
ISPD14275	62	XCEPD1	65	XCSF120B	24	XIF416S7	125
ISPD14440	62	XCEPD2	65	XCSF120C	24	XISD09FM	142
ISPD1444G	62	XCEPD3	65	XCSF120CP	24	XISD09PF	142
NU0851	155	XCEPMTW	65	XCSF120DP	24	XISD09PM	142
NUPUTUK50	155	XCEPRCC	65	XCSF240B	25	XISD15FM	142
PR001	158	XCEPRCP	65	XCSF240C	25	XISD15PF	142
PR002	158	XCEPSS	65	XCSF240CP	25	XISD15PM	142
PR003	157	XCKB	153	XCSF240DP	25	XISD25FM	142
PR004	158	XCKBG	153	XCSF240G	26	XISD25PF	142
PR005	157	XCKPT	153	XCSF30B	22	XISD25PFL	143
PR006	157	XCKR16	109	XCSF30C	22	XISD25PM	142
PR007	157	XCKR25	109	XCSF500C	27	XISD25PML	143
PR009	158	XCKS	153	XCSF500D	27	XISD37FM	142
PR010	158	XCKS15E	134	XCSF500G	28	XISD37PF	142
PR901	158	XCKS15NA	133	XCSF565	29	XISD37PFL	143
PR903	157	XCKS15NB	133	XCSF85B	23	XISD37PM	142
PR904	158	XCKS1S	136	XCSF85C	23	XISD37PML	143
PR905	157	XCKS22	134	XCSF85CP	23	XMBC2K	60
PR906	157	XCKX2	153	XCSG2401C	46	XNPNPNP	99
PR907	157	XCL1R	53	XCSG2401D	46	XO332060	130
PR909	158	XCL5R	53	XCSG2401G	47	XO332240	130
PR910	158	XCLP08CC	151	XCSG2401R	47	XR041E1A	120
PTCCK42	154	XCLP16CC	151	XCSG240C	42	XR041E2A	112
X756340	89	XCLT08AC	150	XCSG500C	43	XR041E24P	113
X756360	88	XCLT08CC	150	XCSG500D	43	XR041E2A	121
X756370	90	XCLT16AC	150	XCSG500G	43	XR041EAD	114
X756510	83	XCLT16CC	150	XCSG720C	44	XR041S24F	139
X756516	82	XCM1A012	106	XCSG720D	44	XR041U24F	115
X756517	82	XCM1A024	106	XCSG960C	45	XR042E24	116
X756524	97	XCM1A120	106	XCSG960D	45	XR042E24P	117
X756526	87	XCM1A230	106	XCSG960G	45	XR042EAD	118
X756527	87	XCM1C012	103	XCSL120C	32	XR042S24	137
X756530	84	XCM1C024	103	XCSL240C	33	XR042T24	138
X756531	84	XCM1C048	103	XCSL85C	31	XR081E1A	120
X756532	84	XCM1C110	103	XCSP120C	32	XR081E24	112
X756533	85	XCM1S024	131	XCSP240C	33	XR081E24P	113
X756534	85	XCM1S024E	131	XCSP85C	31	XR081E2A	121
X756535	85	XCM1T024	132	XCSUP51	56	XR081EAD	114
X756536	86	XCM1T024E	132	XCSUP52	56	XR081S24F	139
X756537	86	XCM2A012	106	XCSW120B	35	XR081U24F	115
X756538	86	XCM2A024	107	XCSW120C	35	XR082E24	116
X756539	83	XCM2A120	107	XCSW121B	36	XR082E24P	117
X756540	94	XCM2A230	107	XCSW121C	36	XR082EAD	118
X756541	94	XCM2C012	104	XCSW121DP	36	XR082S24	137
X756542	94	XCM2C024	104	XCSW240C	37	XR082T24	138
X756816	91	XCM2C048	104	XCSW240D	37	XR161E1A	120
X756817	91	XCM2C110	104	XCSW241B	38	XR161E24	112
X756844	92	XCM4C012	105	XCSW241C	38	XR161E24P	113
X756847	92	XCM4C024	105	XCSW241DP	38	XR161E2A	121
X756894	88	XCMB16B	155	XCSW241G	38	XR161EAD	114
X766082	136	XCMB27B	155	XF03DKBG5B	74	XR161S24F	139
X766083	135	XCOP082	140	XF03DPCG5C	75	XR161U24F	115
X766184	98	XCPC20M	146	XF06DKBG5B	74	XR162E24	116
X766802	154	XCPC26M	146	XF06DPCG5C	75	XR162E24P	117
X766803	154	XCPC34M	146	XF07TDVST2	68	XR162EAD	118
X766804	154	XCPC40M	146	XF100TDVST2	68	XR162S24	137
X766813	154	XCPC50M	146	XF100TYT2	72	XR162T24	138
X766842	110	XCPC60M	146	XF10TYG9	73	XRE1024D	101
X766845	110	XCPC64M	146	XF12DKBG5B	74	XRE1824D	101
X766846	110	XCPD25F	144	XF12DPCG5C	75	XRE2024D	102
X766847	110	XCPD25M	144	XF150TDS84C	69	XR1012D	102
X766848	110	XCPD37F	144	XF16DKCG5B	74	XR1024D	101
XAR1	54	XCPD37M	144	XF16DPCG5C	75	XR1824D	101
XAR6	54	XCPD50F	144	XF16TDVST2	68	XRFA024D	101
XBB125	152	XCPD50M	144	XF16TYT2	72	XRFE16124	128
XBC000	152	XCR41	122	XF180TDS84C	69	XRFE16224	128
XBC010	152	XCR42SC	123	XF200TDS84C	70	XRFE8124	126
XBC225	152	XCR81	122	XF20DKCG5B	74	XRFE8224	127
XBC325	152	XCR83	126	XF20DPCG5C	75	XRMP081CM	120
XBCA00	152	XCRE41	122	XF20TYG9	73	XW000928	95
XBCF00	152	XCRE42SC	123	XF25TYT2	72	XW000929	95
XBS000	152	XCRE81	122	XF300TDS84C	71	XW000930	95
XCAPIP03	81	XCRE83	126	XF30DKCS5B	74	XW000931	96
XCCIS2	93	XCSA120BC	48	XF30DPCG5C	75	XW000932	96
XCCM04SF	147	XCSA120BD	48	XF30TDVST2	68	Z121017	157
XCCM08CV	147	XCSA120CB	48	XF36TYT2	72	Z121019	157
XCCM08SF	147	XCSA120CC	48	XF400TDS84C	71		
XCCM08SV	147	XCSA120DB	49	XF42TDVST2	68		
XCCM12SF	147	XCSA120DC	49	XF50TYT2	72		
XCCM16CV	147	XCSA240FC	50	XF55TDVST2	68		
XCCM16SV	147	XCSB150C	41	XF75TDVST2	68		
XCCM24SV	147	XCSB85C	40	XIF10PML	145		
XCDIN2	156	XCSBC	55	XIF10PMS	145		
XCDIN4	156	XCSBD	59	XIF14PML	145		
XCDIN5	156	XCSBP30Y	57	XIF14PMS	145		
XCDINM45	156	XCSC120B	58	XIF16PML	145		
XCDM08AC	149	XCSC120C	58	XIF16PMS	145		
XCDM08CC	149	XCSD15B	17	XIF16S7	125		
XCDM08CS	148	XCSD15C	17	XIF20PML	145		
XCDM16AC	149	XCSD30C	18	XIF20PMS	145		
XCDM16CC	149	XCSD30E	18	XIF26PML	145		
XCDM16CS	148	XCSD30F	18	XIF26PMS	145		
XCDM24AC	149	XCSD50B	19	XIF34PML	145		
XCDM24CC	149	XCSD70C	20	XIF34PMS	145		